

User Authentication - 2

INFR11158/11230 Usable Security and Privacy

Dr. Jingjie Li

26/01/2024



THE UNIVERSITY
of EDINBURGH

Overview

- Reminder, warm-up, and recap
- Biometrics
- Take-home

Reminder

- Tutorial starting next Monday 10am! (finally :))
- Blog related questions and discussion



Anyone know what is this?



Why it expires on 31 Dec 2024?

Why Does My BRP Expire on 31 December 2024? <https://immigrationbarrister.co.uk/why-does-my-brp-expire-on-31-12-2024/#::~text=Your%20leave%20to%20remain%20will,expire%20on%2031%20December%202024.>
<https://intranet.birmingham.ac.uk/student/international/myrts/forms/brp-card.aspx>

Authentication

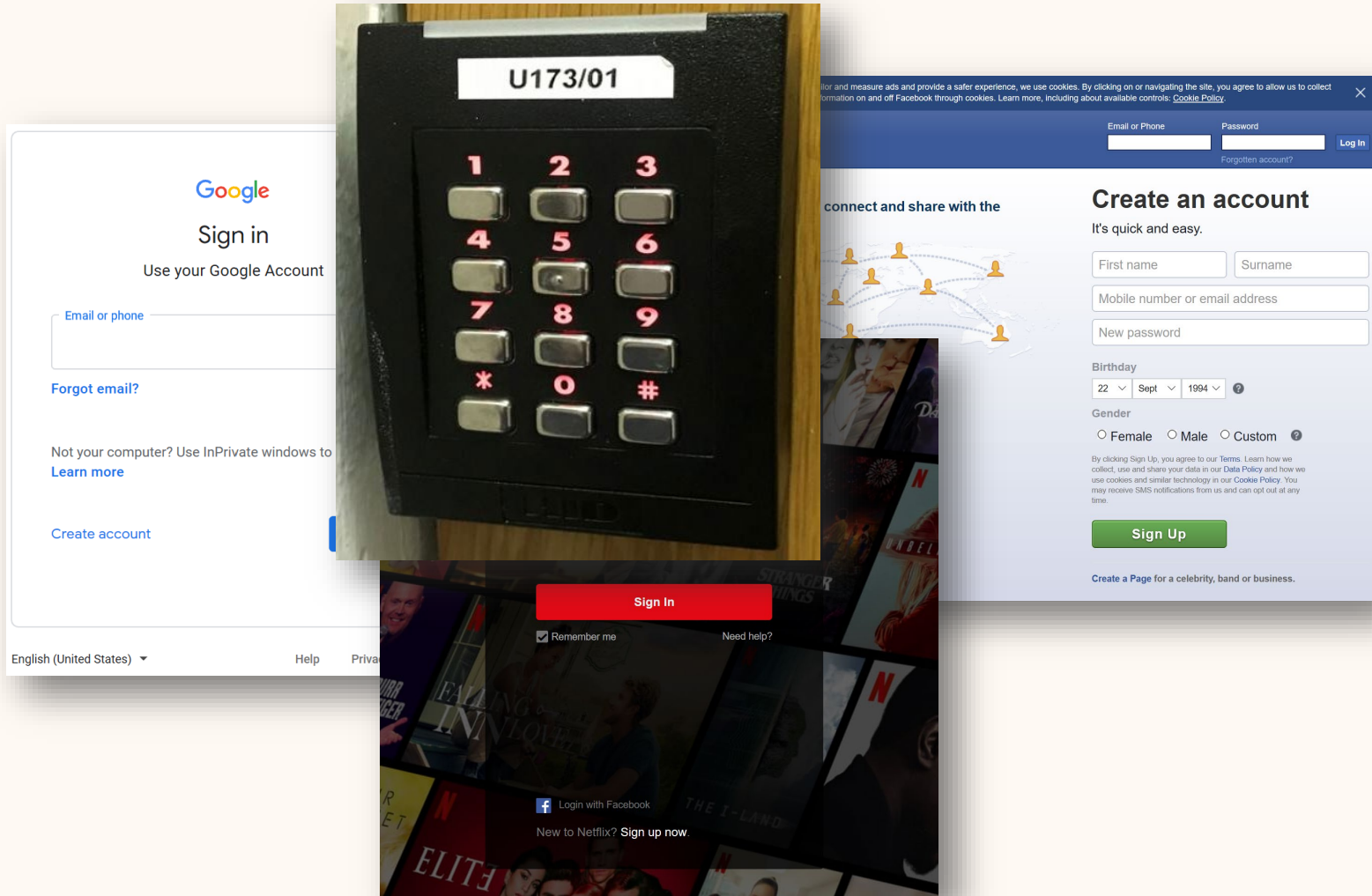

What you know

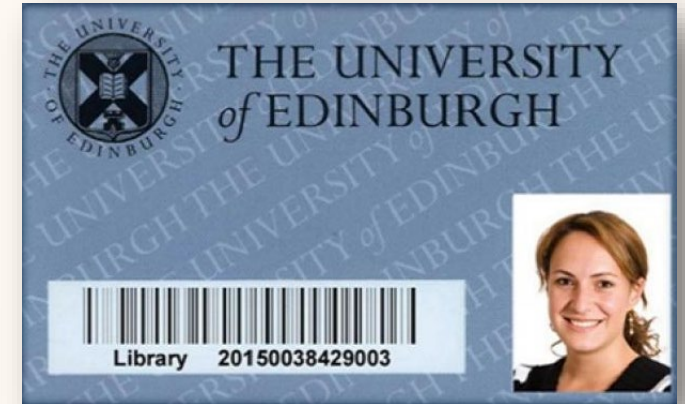

What you have

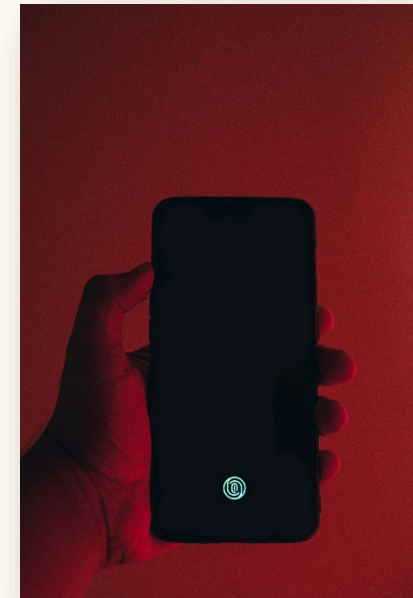

Who you are

Usable Authentication is:

- User friendly
- Reasonable to implement
- Protects against attacks

One time password over SMS

Good Poor Bad

User friendly

- ↑ • Memory effortless
- ↑ • Scalable for users
- ↓ • Nothing to carry
 - Physically effortless
- Easy to learn
- ↓ • Efficient to use
 - Infrequent errors
- ↓ • Easy to recover from loss

Reasonable to implement

- ↓ • Accessible
- ↓ • Negligible cost per user
- ↓ • Server compatible
 - Browser compatible
 - Mature
 - Non-proprietary

Protects against attacks

- Resilient to:
 - ↑ • Physical observation
 - ↑ • Targeted impersonation
 - ↑ • Throttled guessing
 - ↑ • Unthrottled guessing
 - ↓ • Internal observation
 - ↑ • Leaks from other verifiers
 - ↑ • Phishing
 - ↓ • Theft
- ↓ • No trusted third party
 - Requiring explicit consent
 - Unlinkable

Physiological



DNA

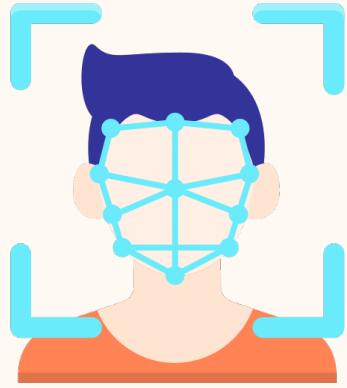

Faceprint

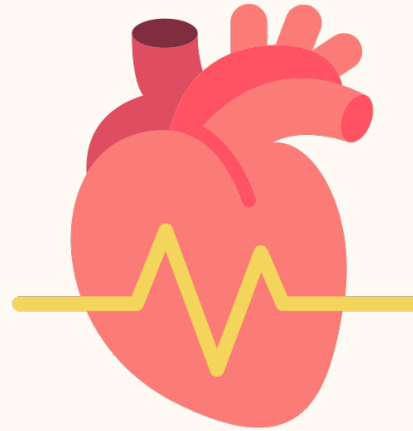

Heartbeat



palmprint

Behavioural



Gait



Keystroke

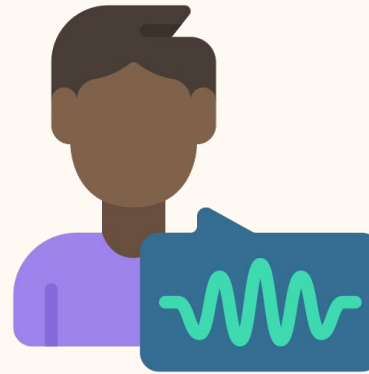

Voiceprint



Signature

Fingerprint: History

- **Prehistoric** potters identify their works with an impressed fingerprint
- **200 BC:** Chinese sign legal documents using fingerprints
- **1400 AD:** Persia used fingerprint for identification
- **1685:** Marcello Malpighi (University of Bologna), formalized fingerprint, introduced ridges, minutiae points
- **1858:** The British started using fingerprint in India (Hoogly district, Bengal) to sign contracts
- **1880s:** Scientists (including Charles Darwin) began observing fingerprints for identification
- **1903:** NYC State Prison started using fingerprinting inmates
- **1905:** US army started using fingerprints for personal identification
- **1924:** FBI Identification Division to collect and consolidate fingerprints
- **2012:** Automated Fingerprint Identification System (AFIS)

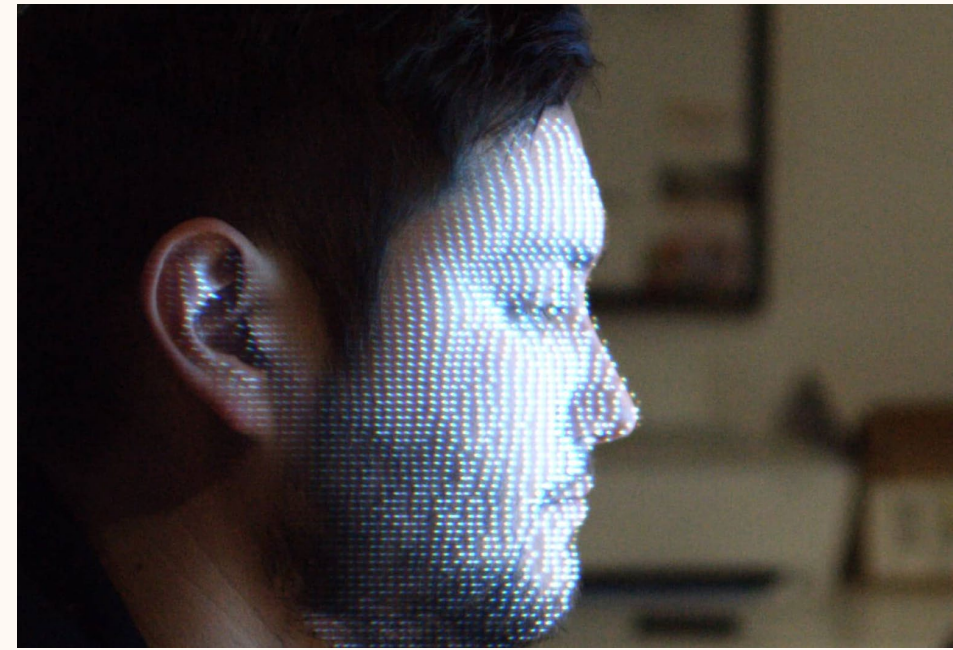

Face ID: more than an image

“The TrueDepth camera captures accurate face data by projecting and analyzing thousands of invisible dots to create a **depth map** of your face and also captures **an infrared image** of your face.” – Apple

Emerging Biometrics: Earable

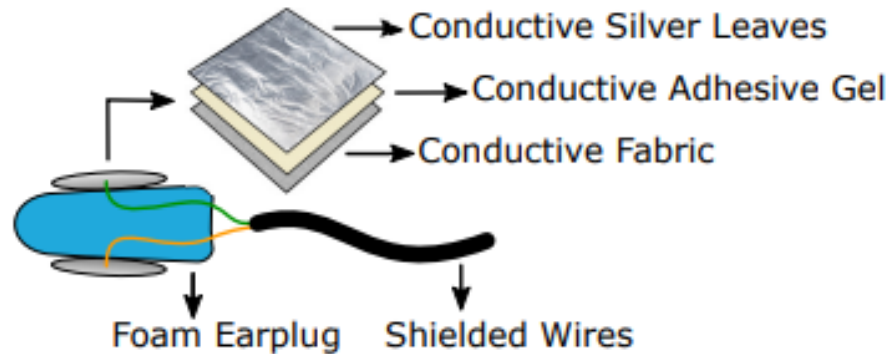

(a) The electrode structure built in LIBS

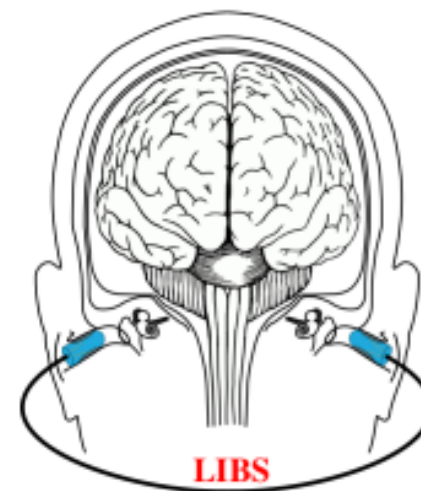
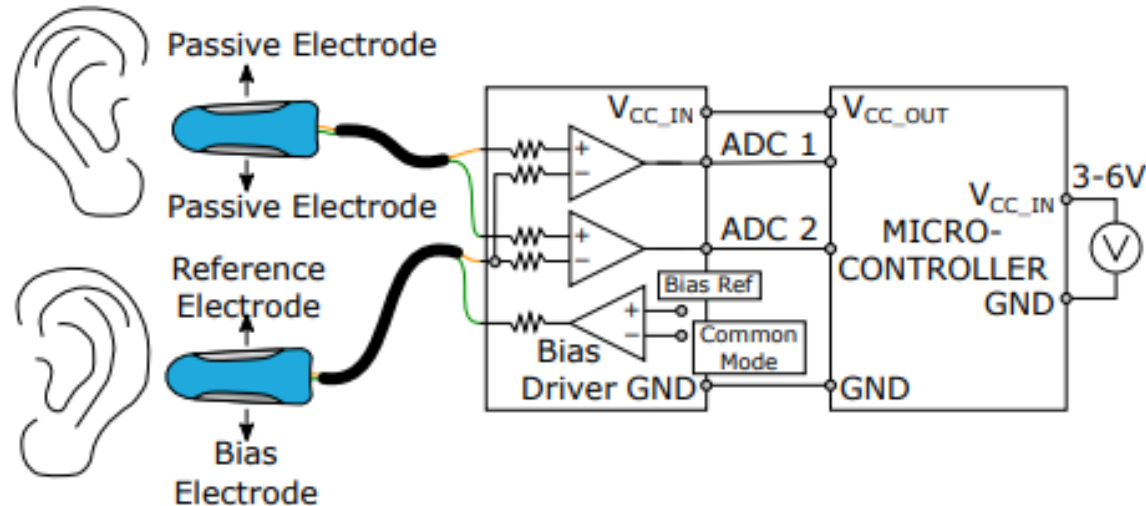

(a) Front view

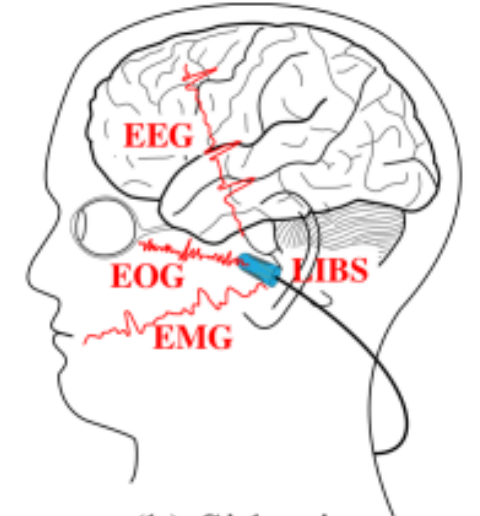

(b) Side view

Nguyen, Anh, Raghda Alqurashi, Zohreh Raghebi, Farnoush Banaei-Kashani, Ann C. Halbower, and Tam Vu. "A lightweight and inexpensive in-ear sensing system for automatic whole-night sleep stage monitoring." In *Proceedings of the 14th ACM Conference on Embedded Network Sensor Systems CD-ROM*, pp. 230-244. 2016.

Emerging Biometrics: Teeth Interface

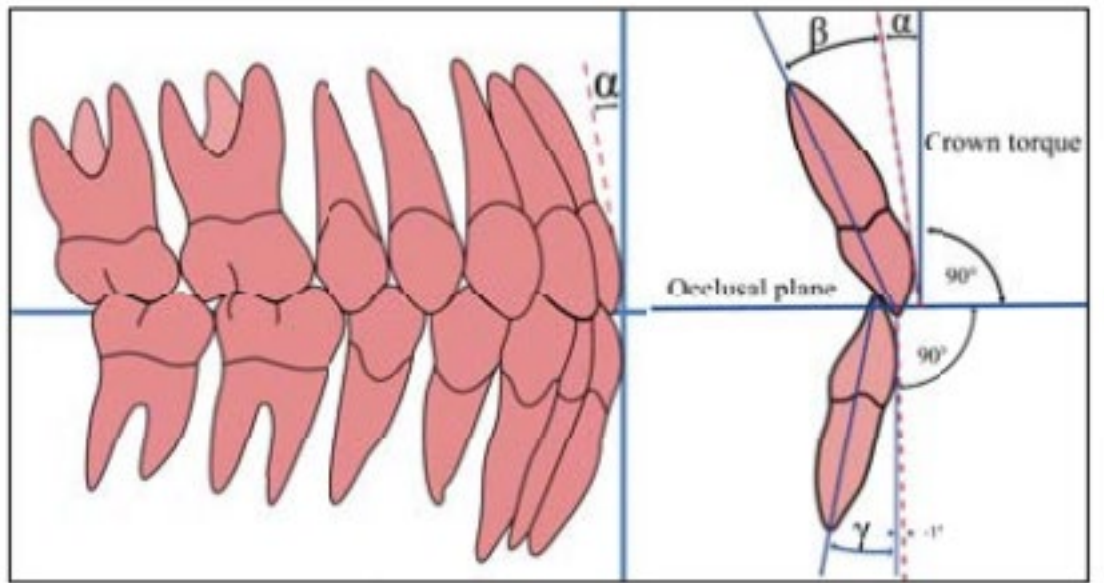

Zou, Y., Zhao, M., Zhou, Z., Lin, J., Li, M. and Wu, K., 2018. BiLock: User authentication via dental occlusion biometrics. *Proceedings of the ACM on Interactive, Mobile, Wearable and Ubiquitous Technologies*, 2(3), pp.1-20.

Emerging Biometrics: Bone Conduction

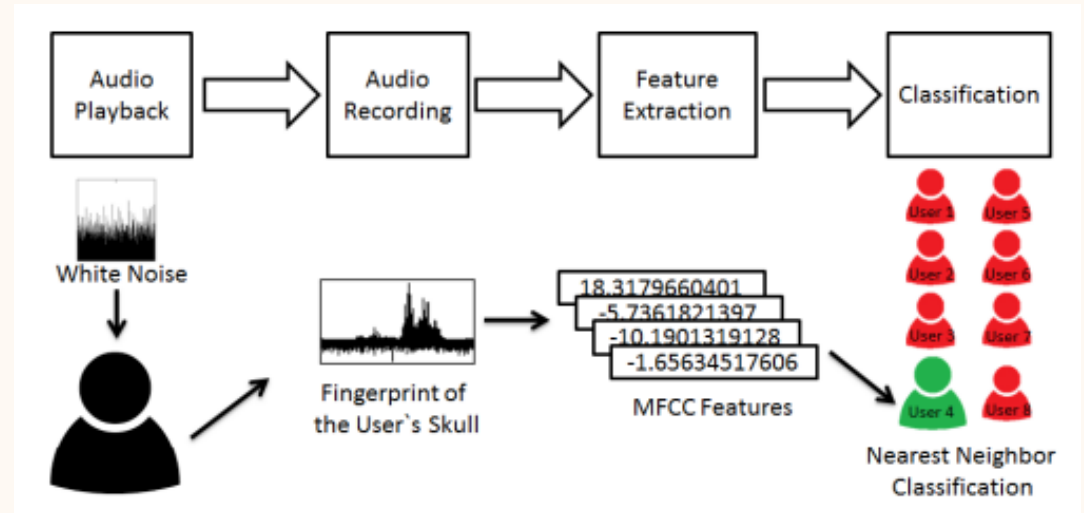
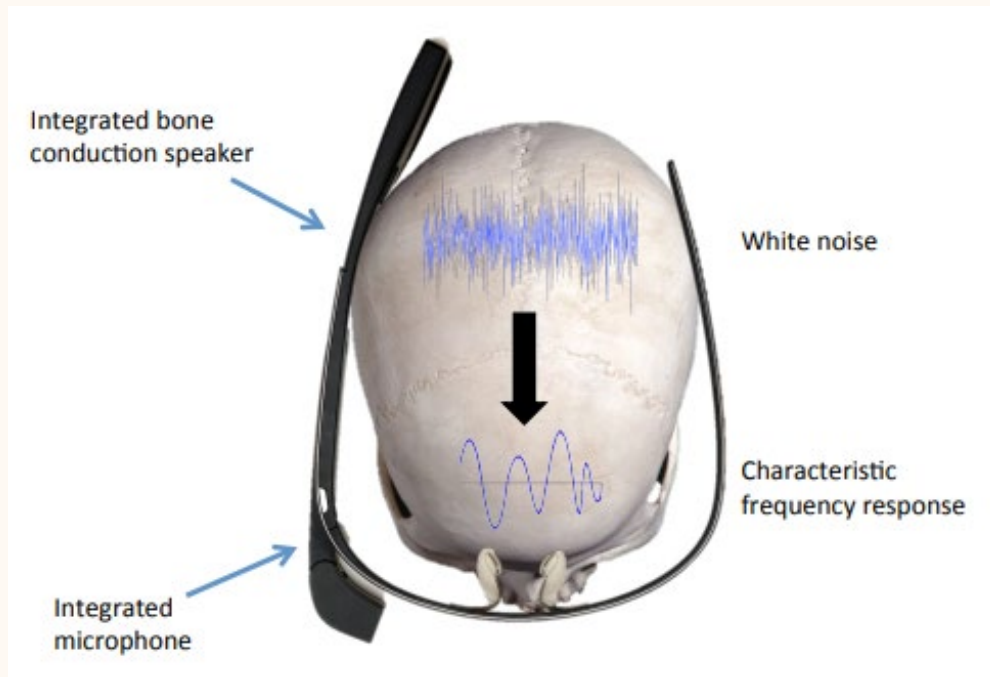

Schneegass, Stefan, Youssef Oualil, and Andreas Bulling. "SkullConduct: Biometric user identification on eyewear computers using bone conduction through the skull." In *Proceedings of the 2016 CHI Conference on Human Factors in Computing Systems*, pp. 1379-1384. 2016.

Emerging Biometrics: VR Motion

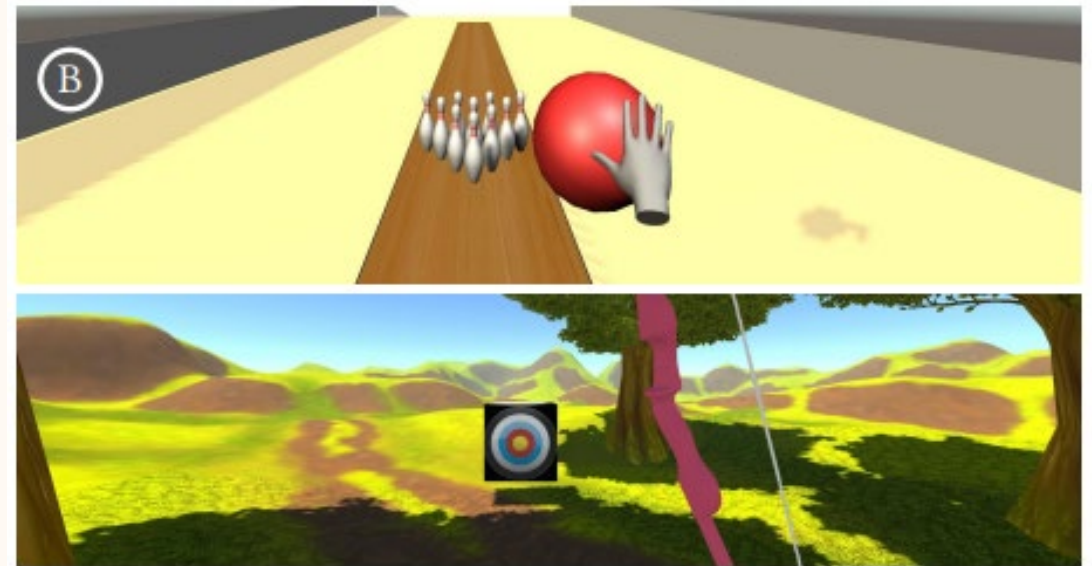
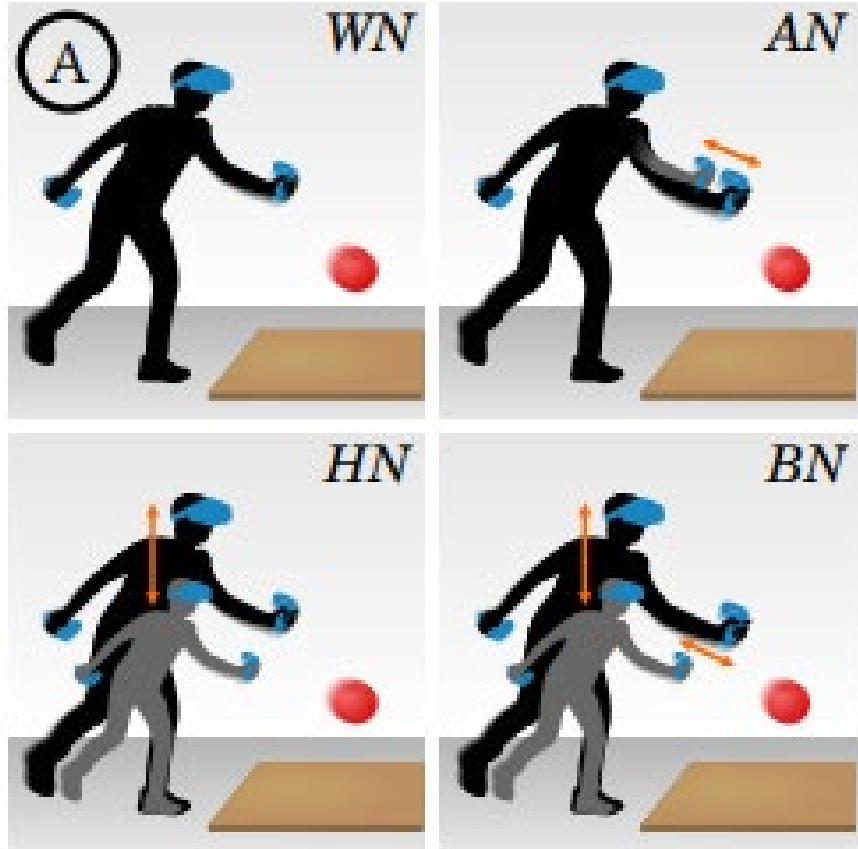

Liebers, Jonathan, Mark Abdelaziz, Lukas Mecke, Alia Saad, Jonas Auda, Uwe Gruenefeld, Florian Alt, and Stefan Schneegass. "Understanding user identification in virtual reality through behavioral biometrics and the effect of body normalization." In *Proceedings of the 2021 CHI Conference on Human Factors in Computing Systems*, pp. 1-11. 2021.

Fingerprint vs. Face ID? Which one do you prefer?

Attributes of a “good” biometric feature

1. **Universality:** Does everyone have it?
2. **Distinctiveness:** Is it different for everyone?
3. **Permanence:** Does the feature change over time/age?
 - bad: face, good: fingerprint
4. **Collectability:** How easy it is to collect/measure the feature?
 - Very hard: DNA, relatively easy: fingerprint
5. **Performance:** How difficult to match?
6. **Acceptability**
7. **Circumvention:** How easy to spoof?
 - Voice recognition

Identification vs. Authentication? What is the difference?

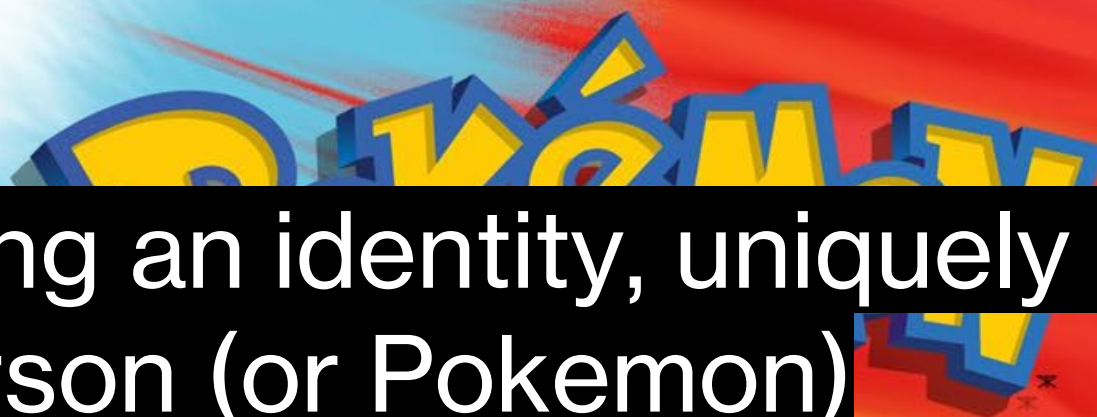

Identification: Claiming an identity, uniquely identifying a person (or Pokemon)



I am
Pikachu



I am
Pikachu



I am
Pikachu

Authentication: proving the identity



Fingerprint: How does it work?

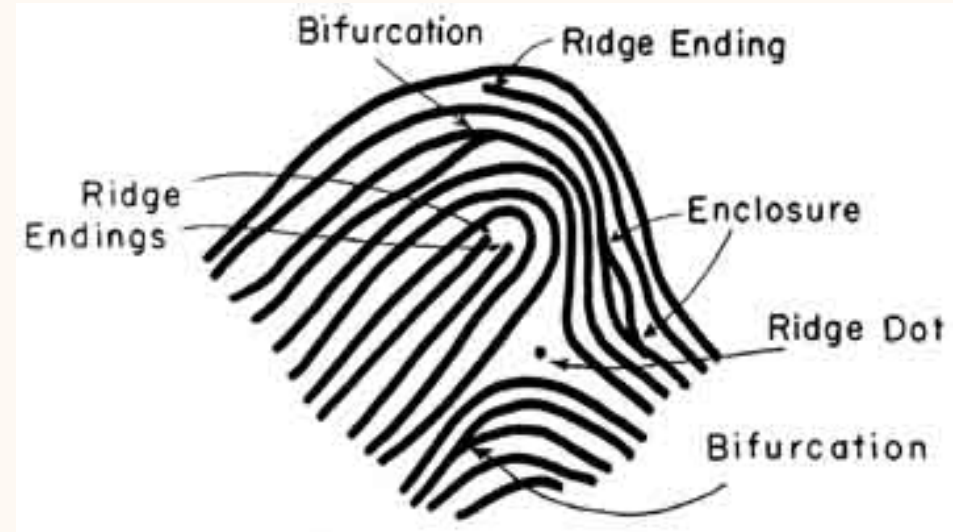

Image acquisition

Optical, Capacitive, Ultrasound sensors



Image processing



Minutiae extraction

Store f in the database with username

$$f = \{(x_1, y_1, \theta_1), (x_2, y_2, \theta_2), \dots, (x_n, y_n, \theta_n)\}$$

Fingerprint Matching

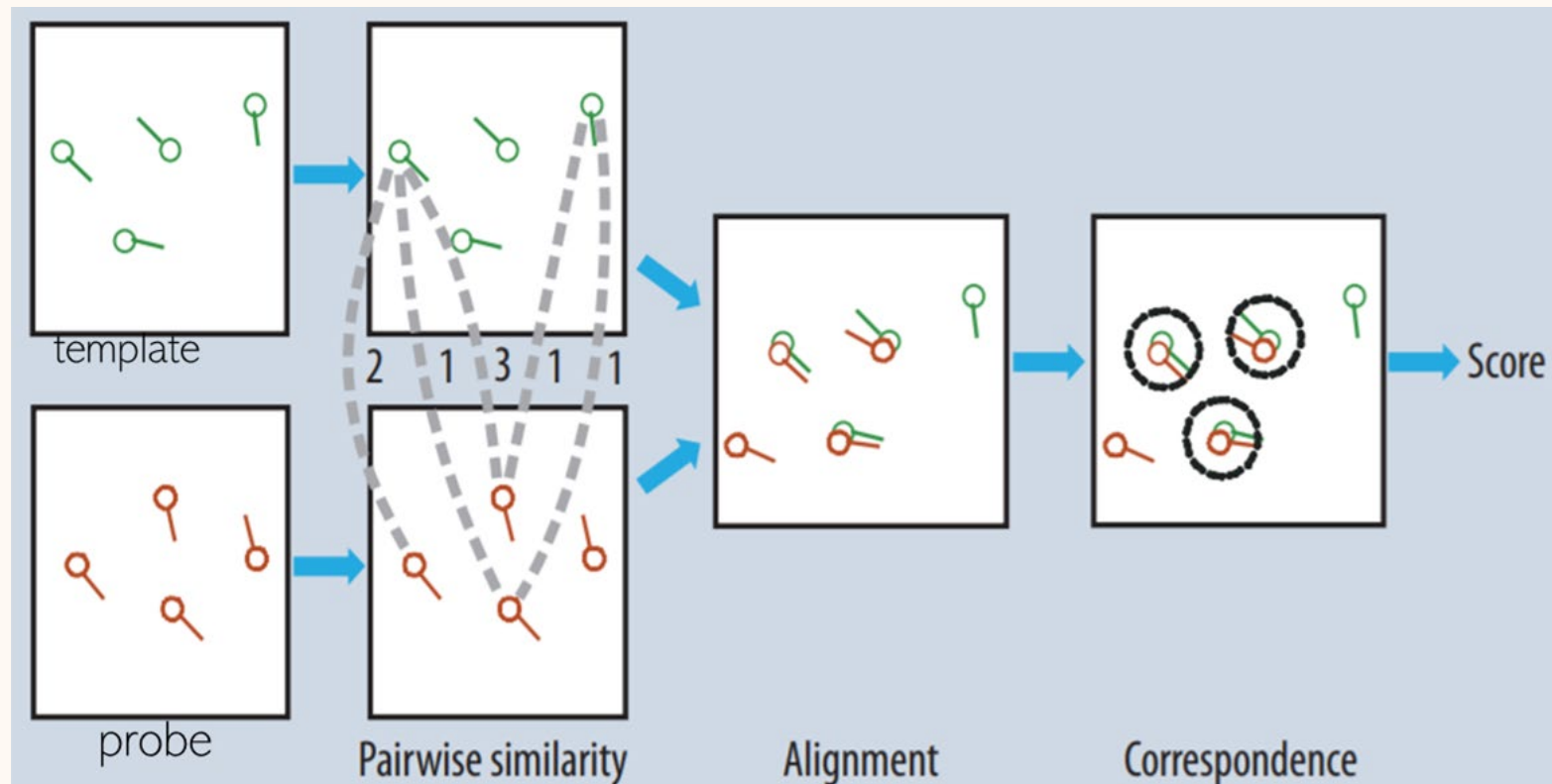
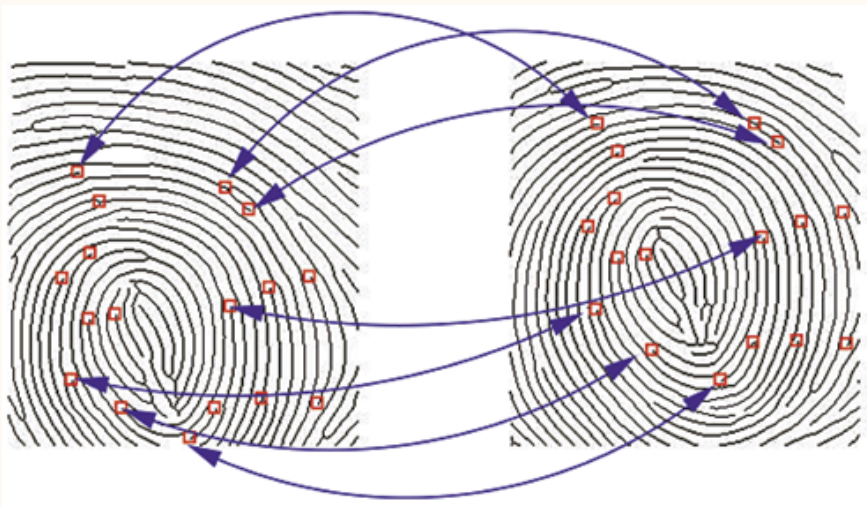

Matching Accuracy

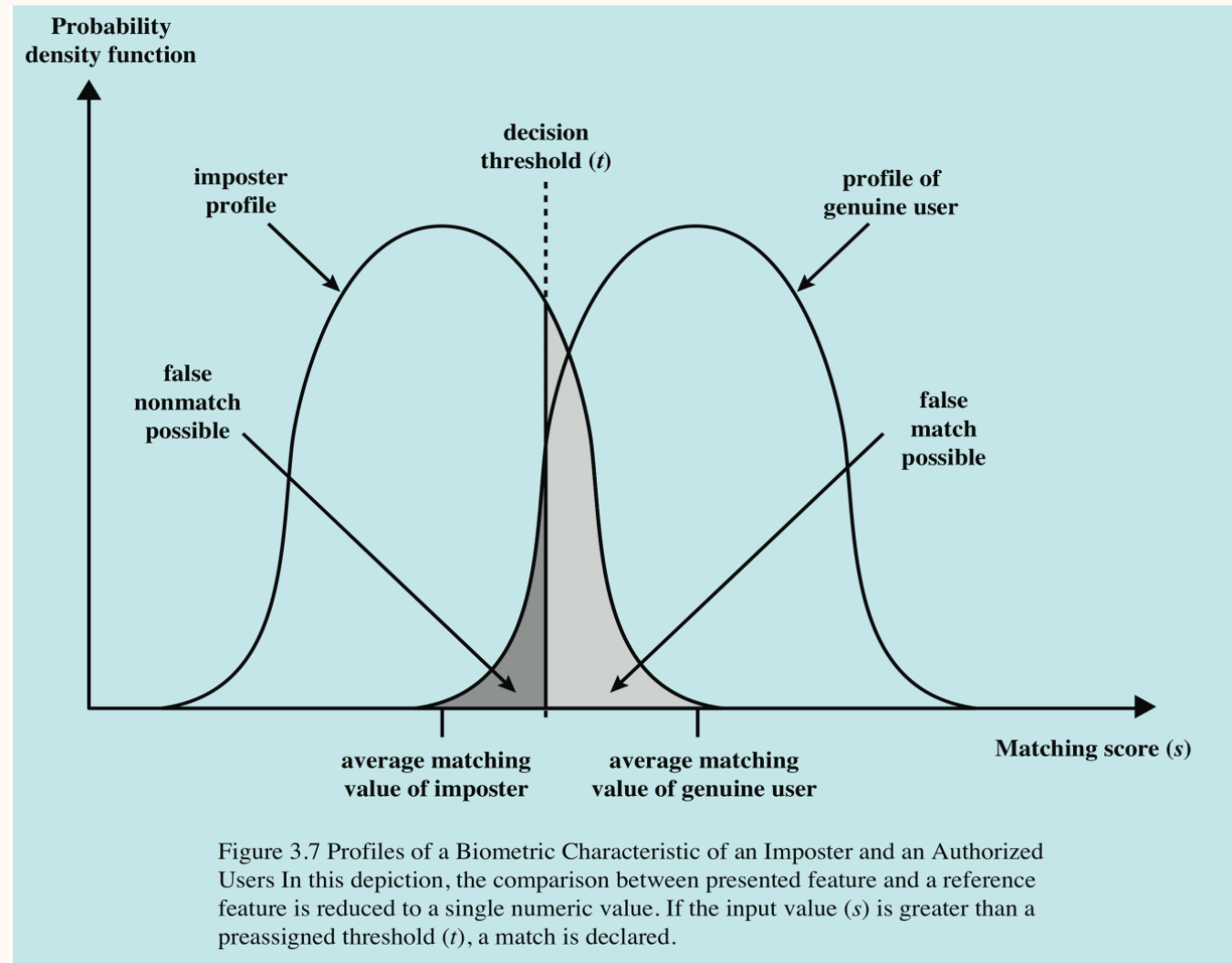

Matching Accuracy

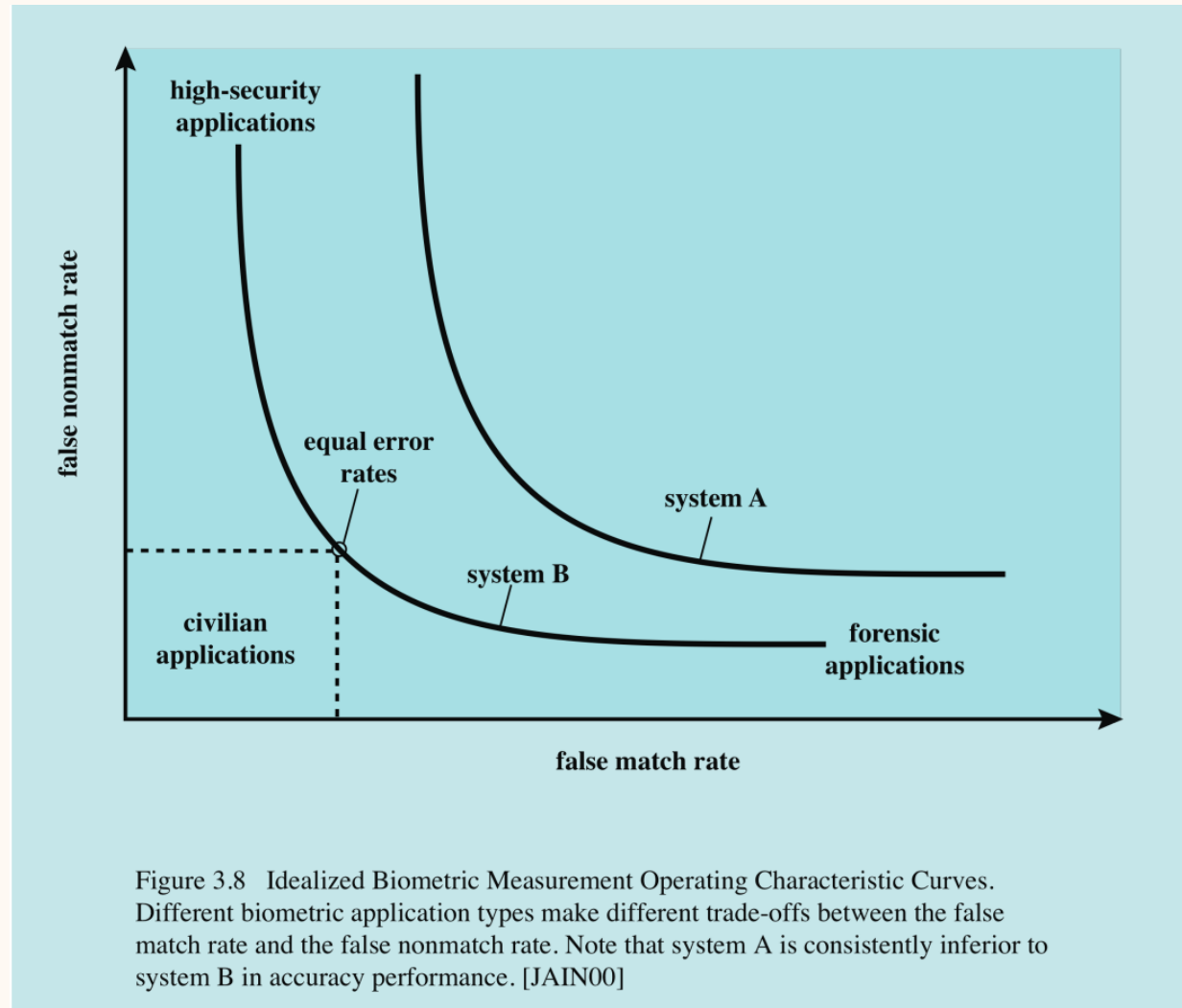

Challenge with Biometrics

- **Low accuracy**

- High False Non-Matching Rate (FNMR) (a.k.a false rejection rate (FRR))
- iPhone fingerprint matching has 1 in 50,000 false matching rate (FMR)

- **Noise** from biometric readers

- High error rate for **some users**

- Speed and scale matching process is **slow**

- **Cannot be hashed**, since every reading is different

- Hash output will be completely different, and therefore cannot match
- Cryptographic hash functions reveal nothing beyond strict equality

Correct – belongs to the **same users** – biometric readings are rejected

Incorrect – belongs to **different users** – fingerprints are accepted

Vascular Pattern

- LED infrared light
- May change overtime



Face Recognition

- Location and position of facial features
- Dependent on background and lighting conditions

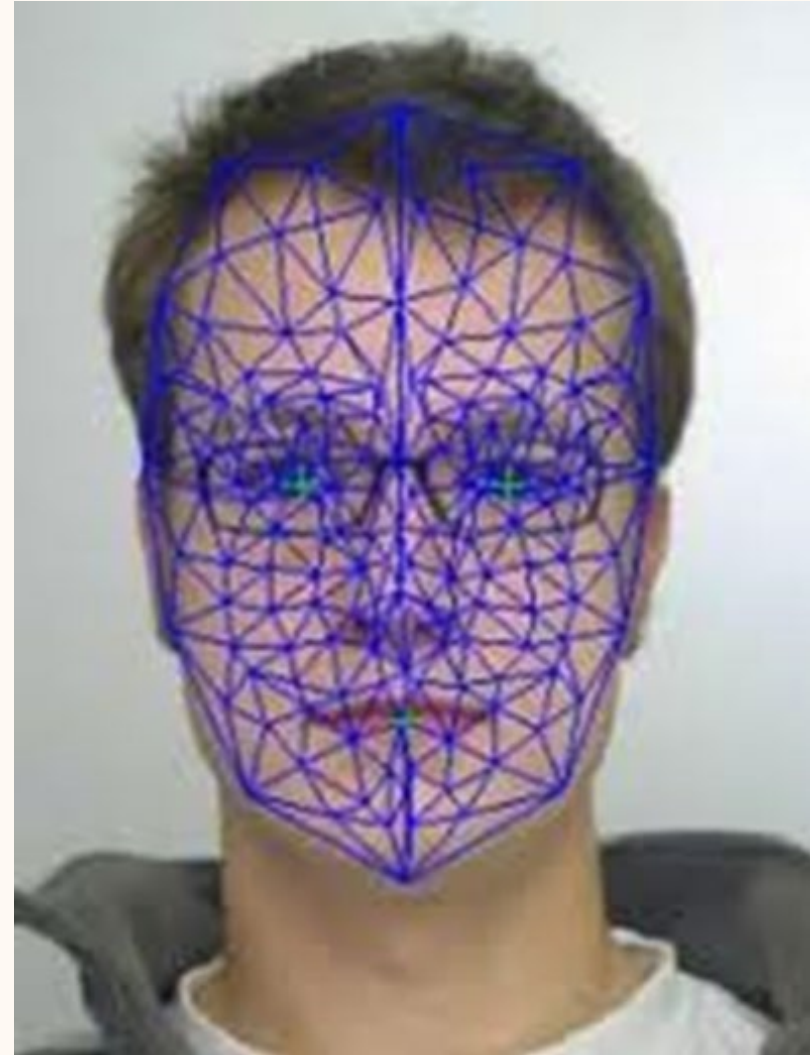

Voice Biometrics

- Factors: pitch, intensity, quality and duration
- Problems: include background noise

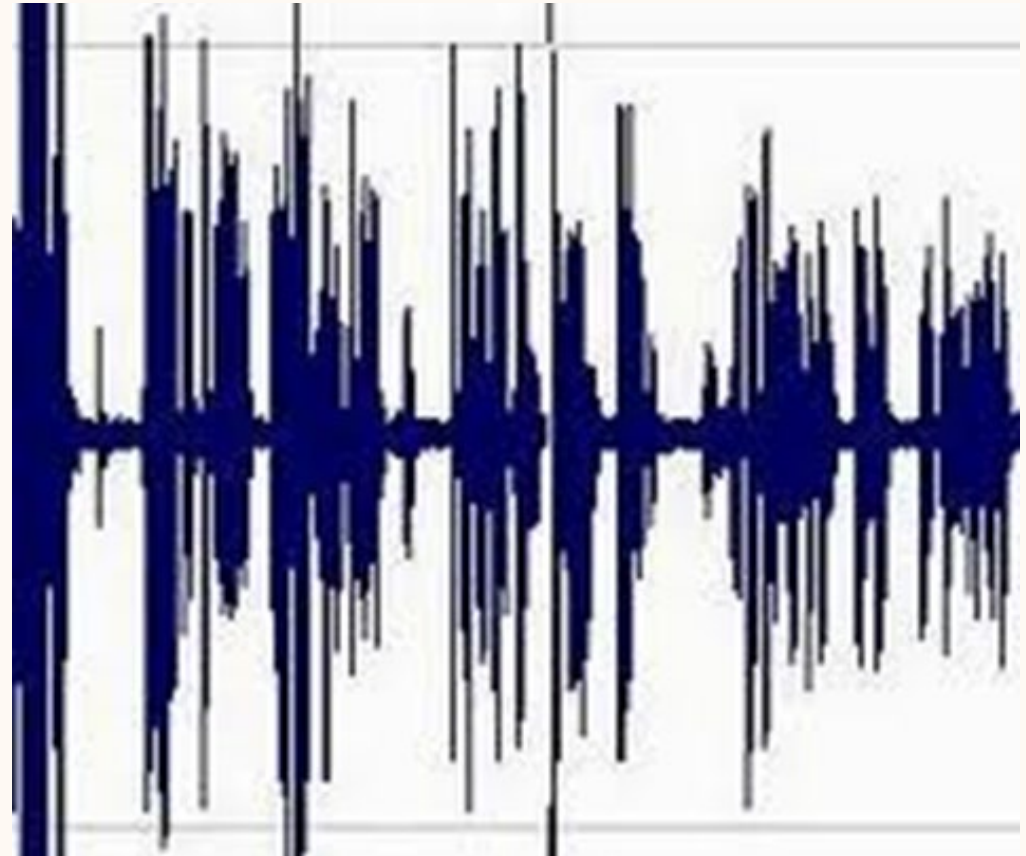

Hand Geometry

- Scan both sides of hand
- Not as accurate as other methods

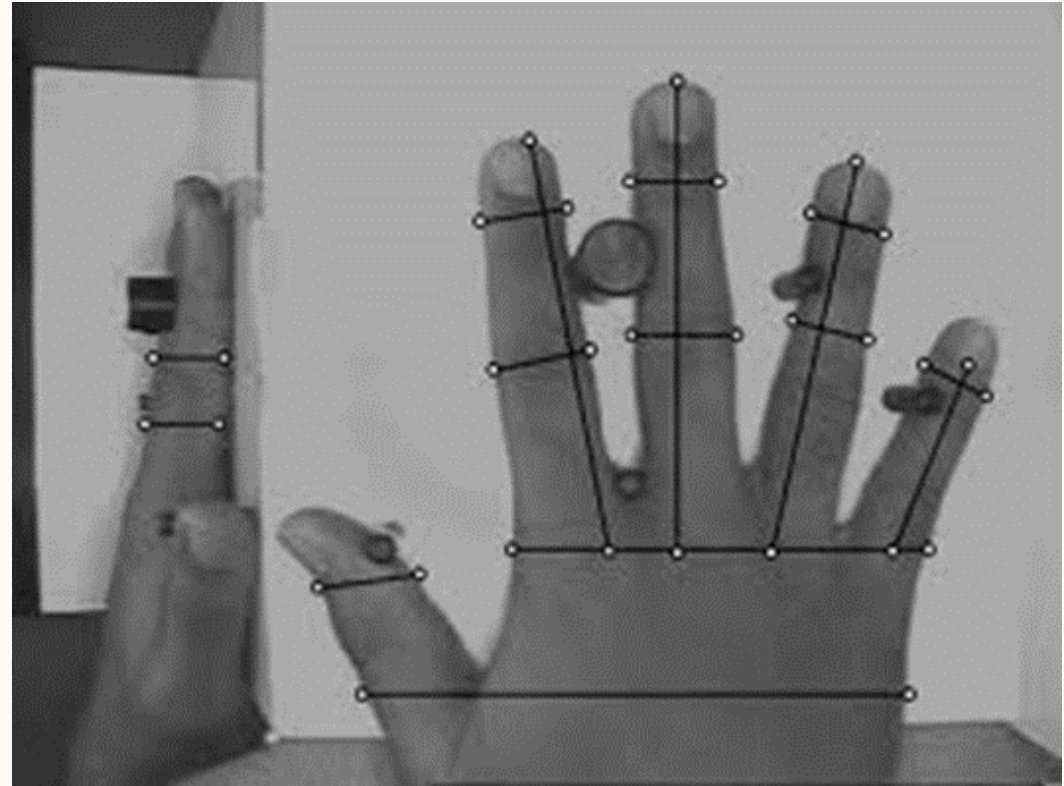

Dynamic Signature

- Factors: velocity, acceleration and speed
- Problems: forgers could reproduce

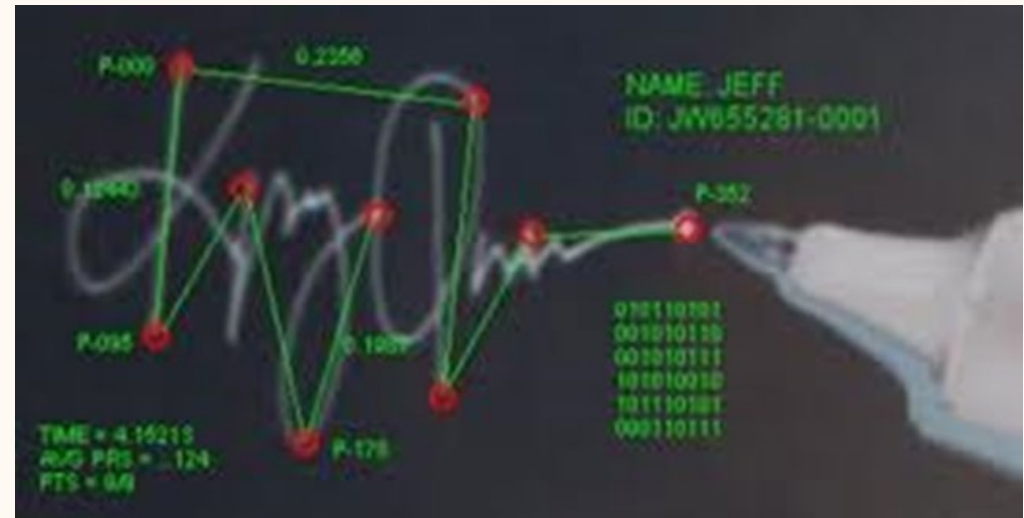

Iris Recognition

- Iris photography using visible or near infrared light
- Subject to environmental conditions

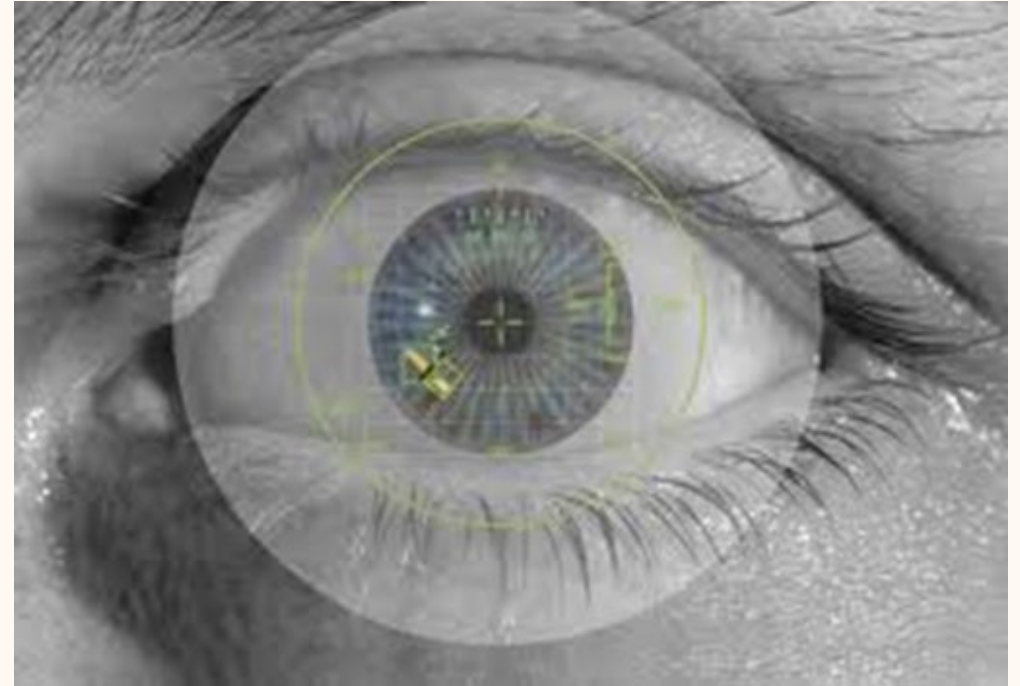

Retina Recognition

- One of the most secure means of biometrics
- Unique to each person
- Unique to each eye
- Problems: intrusive (flashing light into eyes)



Biometrics Application: Commercial

- Computer login
- Electronic Payment
- ATMs
- Record Protection



Biometrics Application: Government

- Passport control
- Border control
- Access Control



Biometrics Application: Forensic

- Missing persons
- Corpse identification
- Criminal investigations



What could go wrong?



User



Terminal



Network



Server

Model

**Your biometrics
are not safe!**



- Shoulder-surfing
- Network sniffing
- Storage compromise
- Model poisoning
- ... (many other surfaces!)

ORIGINAL

DERPFAKE



THE DECISION

THE DECISION



Challenge-Response Biometrics Authentication

Session 6A: Biometrics Security

CCS '19, November 11–15, 2019, London, United Kingdom

VELODY: Nonlinear Vibration Challenge-Response for Resilient User Authentication

Jingjie Li

University of Wisconsin–Madison
jingjie.li@wisc.edu

Kassem Fawaz

University of Wisconsin–Madison
kfawaz@wisc.edu

Younghyun Kim

University of Wisconsin–Madison
younghyun.kim@wisc.edu

ABSTRACT

Biometrics have been widely adopted for enhancing user authentication, benefiting usability by exploiting pervasive and collectible unique characteristics from physiological or behavioral traits of human. However, successful attacks on “static” biometrics such as fingerprints have been reported where an adversary acquires users’ biometrics stealthily and compromises non-resilient biometrics.

To mitigate the vulnerabilities of static biometrics, we leverage the unique and nonlinear hand-surface vibration response and design a system called VELODY to defend against various attacks including replay and synthesis. The VELODY system relies on two major properties in hand-surface vibration responses: uniqueness, contributed by physiological characteristics of human hands, and nonlinearity, whose complexity prevents attackers from predicting the response to an unseen challenge. VELODY employs a challenge-response protocol. By changing the vibration challenge, the system elicits input-dependent nonlinear “symptoms” and unique spectrotemporal features in the vibration response, stopping both replay and synthesis attacks. Also, a large number of disposable challenge-

'19), November 11–15, 2019, London, United Kingdom. ACM, New York, NY, USA, 13 pages. <https://doi.org/10.1145/3319535.3354242>

1 INTRODUCTION

The mass proliferation of “smart” devices has created unprecedented security and privacy concerns to their users. One of the significant security concerns comes from unauthorized entities accessing and controlling user devices. Stronger access control goes a long way towards alleviating security and privacy threats to users and their devices. User authentication, where a user has to prove their identity to a system, is one core mechanism to achieve adequate access control.

Biometric user authentication, which relies on the unique physiological or behavioral traits of the user to verify their identity, has been touted as the solution that meets both security and usability goals. Thanks to its low cognitive burden, it is more attractive to the users who wish to authenticate themselves to their devices without having to memorize a password or use an additional security device.

PITFALLS OF REUSING STATIC BIOMETRIC



- **Static:** reusing same information
- **Non-resilient:** cannot be recovered

CHALLENGE-RESPONSE BIOMETRIC



- **Modality:** respond dynamically to different stimuli (challenges)
- **Security:** harvest sufficient secret keys
- **Usability:** enroll and authenticate with low effort

VELOCITY: OVERVIEW

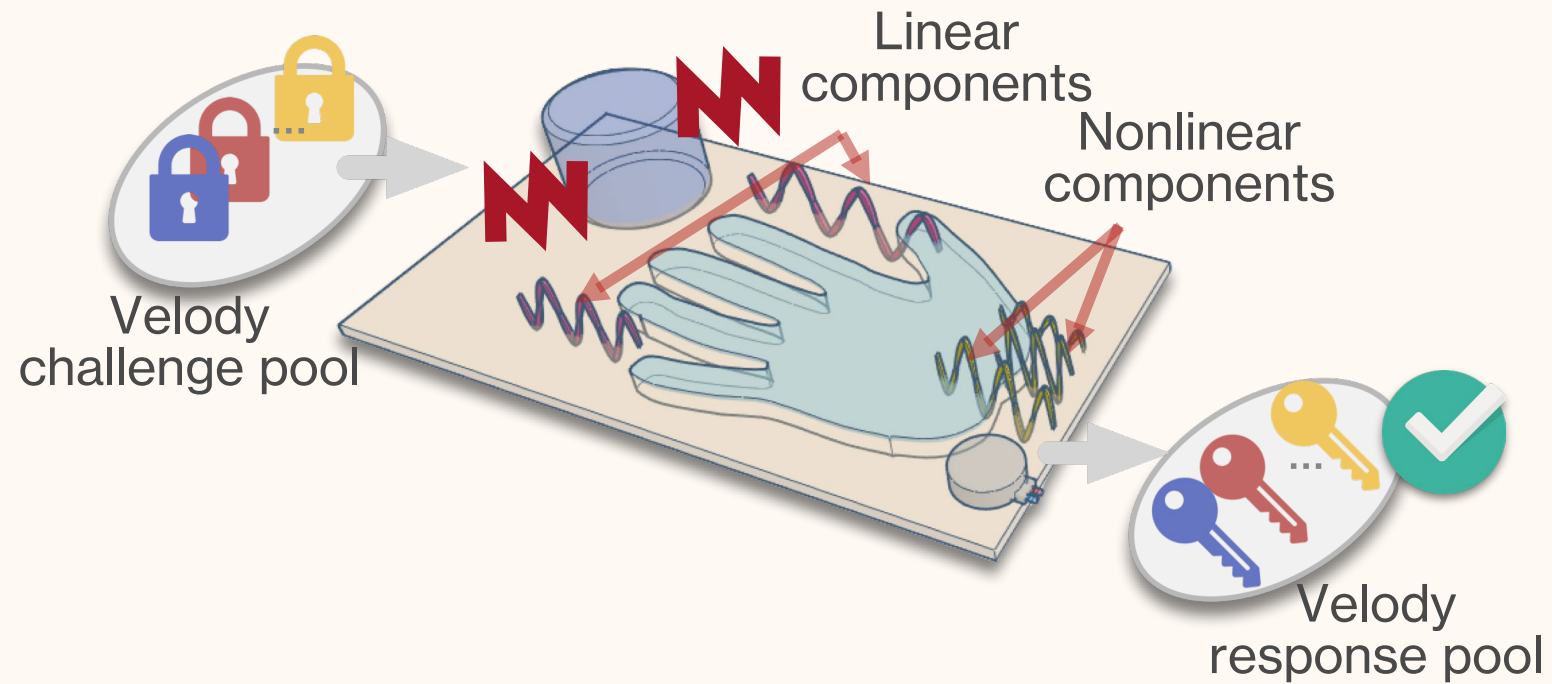

UNIQUE HAND-SURFACE VIBRATION

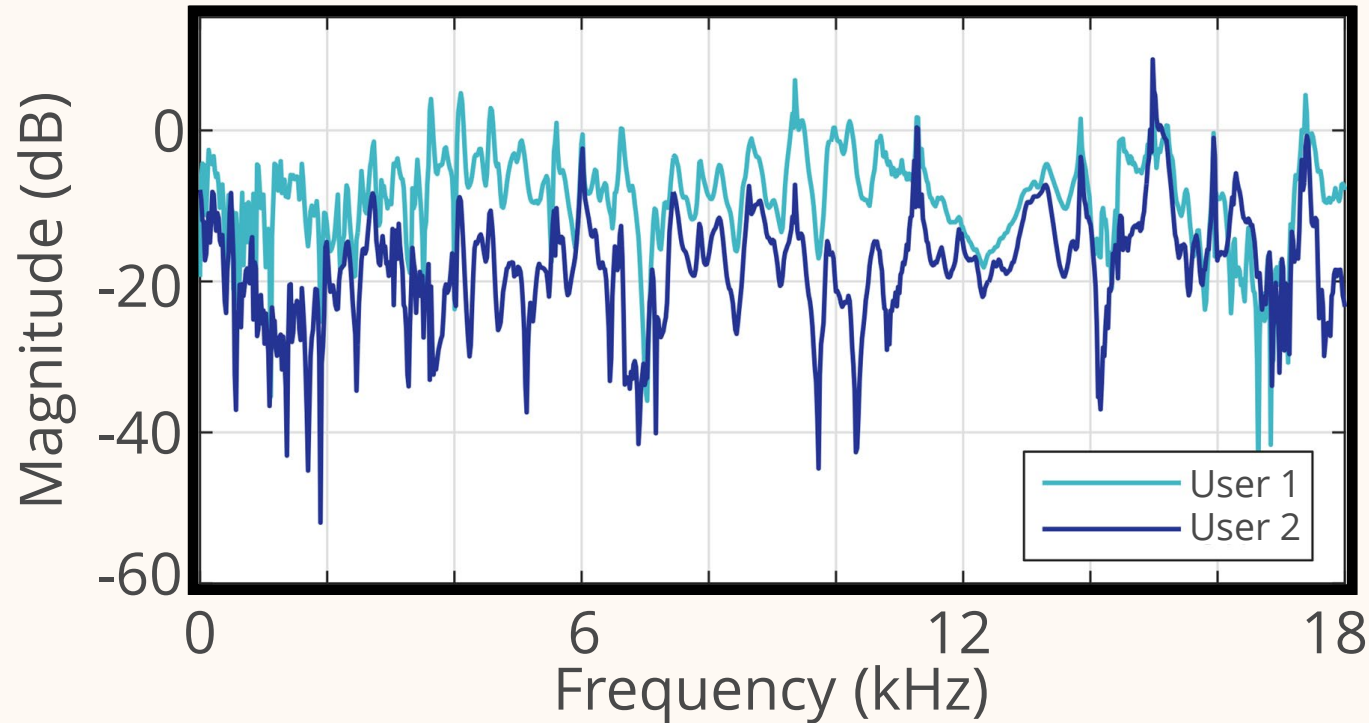

Hand-surface vibration responses of frequency chirp

- Vibration as an **interaction** modality
- Vibration for user **identification** (VibID, 2016) and **authentication** (VibWrite, 2017)
- **Uniqueness** from different hand geometries and compositions

Yang, L., Wang, W. and Zhang, Q., 2016, April. Vibid: User identification through bio-vibrometry. In Proceedings of the 15th International Conference on Information Processing in Sensor Networks (p. 11). IEEE Press.

Liu, J., Wang, C., Chen, Y. and Saxena, N., 2017, October. VibWrite: Towards finger-input authentication on ubiquitous surfaces via physical vibration. In Proceedings of the 2017 ACM SIGSAC Conference on Computer and Communications Security (pp. 73-87). ACM.

BACKGROUND: NONLINEAR VIBRATION RESPONSE

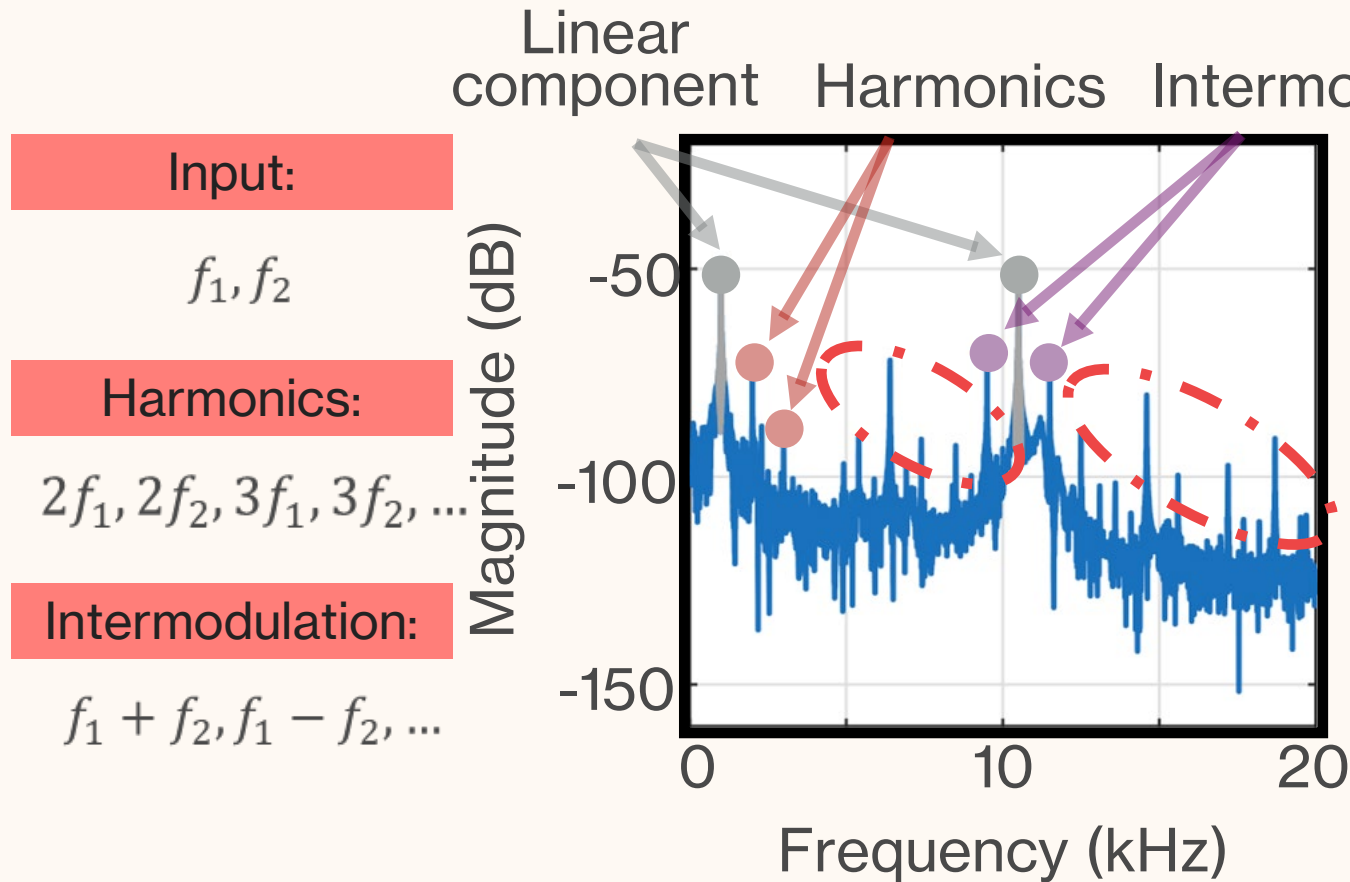

- **Frequency generation** in nonlinear vibration channel
 - **Non-analytic** response dependent on the stimulus-induced state of the channel
- ➔ **Hard to model** hand-surface vibration channel

Experimental Setup

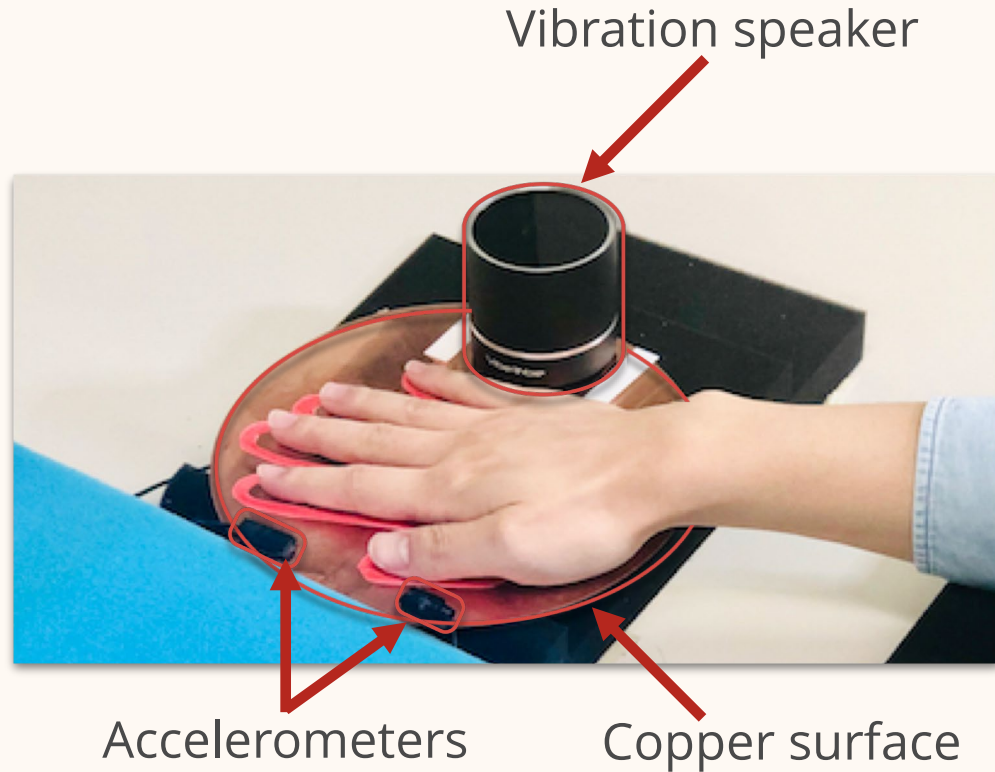

- 15 subjects during 1.5 months (approved by IRB of UW-Madison)
- Session length: 20–30 minutes
- 100 challenges per user
- Enrollment per session: <15 minutes
- Authentication duration: <1 second

Experimental Setup



- 15 subjects during 1.5 months (approved by IRB of UW-Madison)
- Session length: 20–30 minutes
- 100 challenges per user
- Enrollment per session: <15 minutes
- Authentication duration: <1 second

Other Challenge Response Biometrics

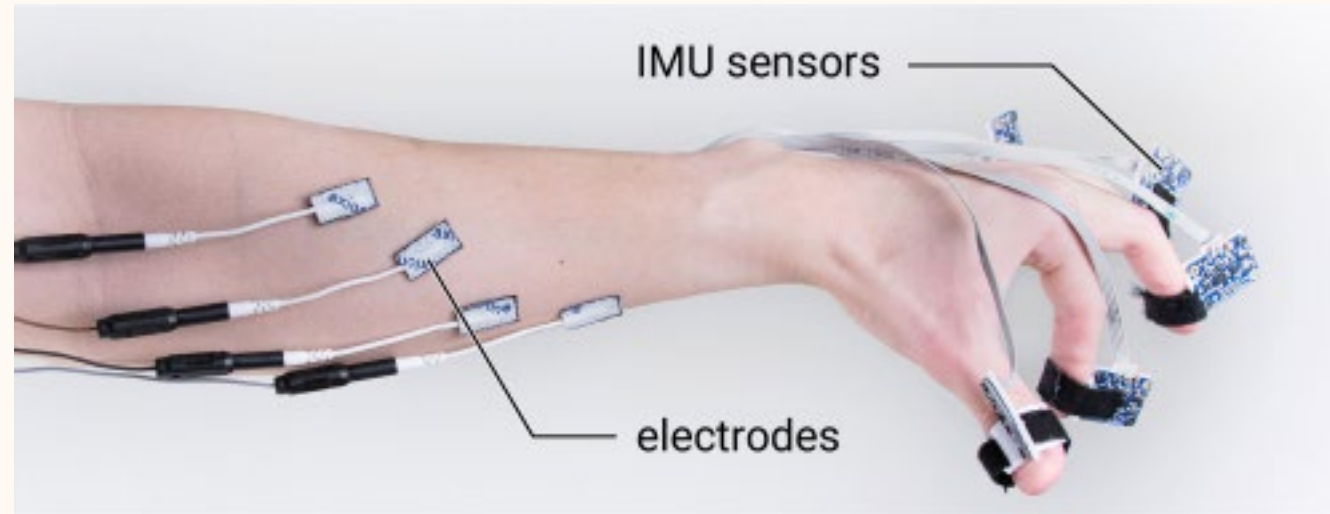

Sluganovic, Ivo, Marc Roeschlin, Kasper B. Rasmussen, and Ivan Martinovic. "Using reflexive **eye movements** for fast challenge-response authentication." In *Proceedings of the 2016 ACM SIGSAC Conference on Computer and Communications Security*, pp. 1056-1067. 2016.

Lin, Feng, Kun Woo Cho, Chen Song, Wenyao Xu, and Zhanpeng Jin. "Brain password: A secure and truly cancelable **brain biometrics** for smart headwear." In *Proceedings of the 16th Annual International Conference on Mobile Systems, Applications, and Services*, pp. 296-309. 2018.

Chen, Y., Yang, Z., Abbou, R., Lopes, P., Zhao, B.Y. and Zheng, H., 2021, May. User authentication via **electrical muscle stimulation**. In *Proceedings of the 2021 CHI Conference on Human Factors in Computing Systems* (pp. 1-15).

What is the usability issue here?

Experts' vs Non-experts' view on biometrics

CHI 2019 Paper

CHI 2019, May 4–9, 2019, Glasgow, Scotland, UK

“Pretty Close to a Must-Have:” Balancing Usability Desire and Security Concern in Biometric Adoption

Flynn Wolf

UMBC

flynn.wolf@umbc.edu

Ravi Kuber

UMBC

rkuber@umbc.edu

Adam J. Aviv

United States Naval Academy

aviv@usna.edu

ABSTRACT

We report on a qualitative inquiry among security-expert and non-expert mobile device users about the adoption of biometric authentication using semi-structured interviews ($n=38$, 19/19 expert/non-expert). Security experts more readily adopted biometrics than non-experts but also harbored greater distrust towards its use for sensitive transactions, feared biometric signature compromise, and in some cases distrusted newer facial recognition methods. Both groups harbored misconceptions, such as misunderstanding of the functional role of biometrics in authentication, and were about equally likely to have stopped using biometrics due to usability. Implications include the need for tailored training for security-informed advocates, better design for device sharing and co-registration, and consideration for usability needs in work environments. Refinement of these features

1 INTRODUCTION

Biometric authentication has the potential to increase the usability of mobile devices. Frequent screen unlocking and application authorization is accomplished with a quick glance or touch rather than recalling and entering long/complex passcodes [19]. Despite the benefits, adoption can be uneven due to usability issues [9, 29] and user misunderstanding or security concern [14].

From a security-conscious perspective, allowing a new technology to record and store a permanent signature of one's self and use it to control access to sensitive data transactions might cause deep concern. Research has documented biometric adoption [2, 25], experts' sophisticated mental models of network security that are distinct from those of everyday users [1, 4, 5, 26, 30, 33], and the influence that usability [12, 15, 16] and similar models of security have

Experts' views

- More influenced by work and BYOD requirements than non-experts
- More likely to have used BAM immediately when available than non-experts
- Change authentication approach more frequently than non-experts
- Device choices more influenced by security concern compared to non-expert

Non-experts' views

- Less concerned than experts about compromise of their biometric signatures
- Less afraid than experts of using biometric unlocking on mobile payment/banking apps
- Less likely than experts to have initially thought consumer biometrics were a good idea

Both's views

- Frequently mistake biometric unlocking as the primary rather than secondary method
- Equally likely to have stopped using biometric unlocking because of usability problems
- Security concern motivated by fear of physical loss/theft
- Similar proportions initially thought consumer biometrics were a bad idea

Questions?

Take-home

- **(Blog)** MIT Technology Review - [The hack that could make face recognition think someone else is you](#)
- **(Blog)** Wang, X. and Zhang, Y., 2021, May. [Nod to auth: Fluent ar/vr authentication with user head-neck modeling](#). In Extended Abstracts of the 2021 CHI Conference on Human Factors in Computing Systems (pp. 1-7).