



THE UNIVERSITY
of EDINBURGH

Advanced Database Systems

Spring 2025

Lecture #08:

Tree-Structured Indexing

R&G: Chapter 10

SORTED FILES AND BINARY SEARCH

Efficient evaluation of range queries

```
SELECT * FROM Customer
WHERE zipcode BETWEEN 8800 AND 8999
```

Sort table on disk by zipcode

Use binary search to find the first qualifying record

Scan as long as zipcode \leq 8999



SORTED FILES AND BINARY SEARCH

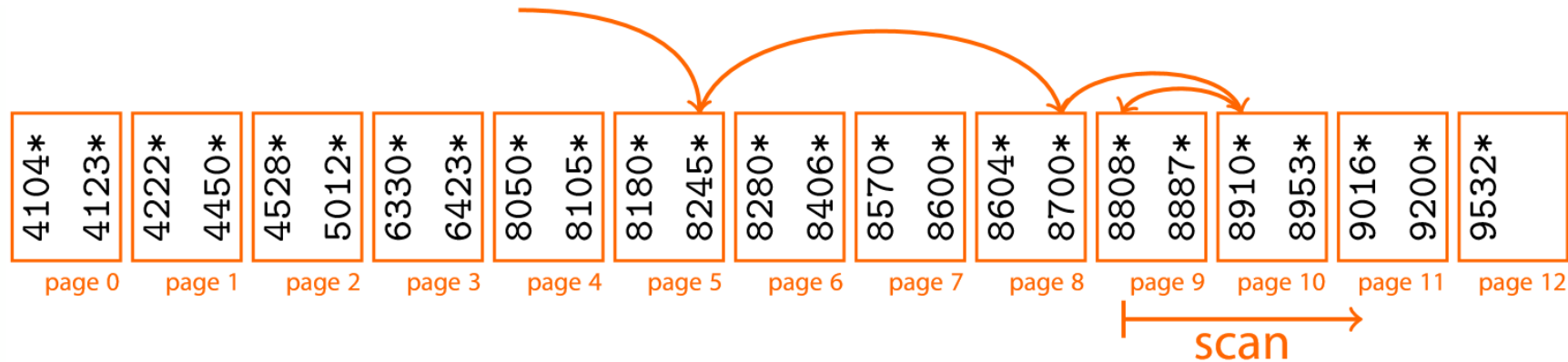

Sequential access during the scan phase

Need to read $\log_2(\#records)$ records during the search phase

Need to read about as many pages ☹️

Fan-out of 2 \rightarrow deep tree \rightarrow lots of I/Os

Make far, unpredictable jumps \Rightarrow bad for page prefetching

TREE-STRUCTURED INDEXING

Two index structures particularly shine with **range selections**

ISAM: Static structure

B+ Tree: Dynamic structure, adjust gracefully under inserts and deletes

Simple idea: Create an 'index' file

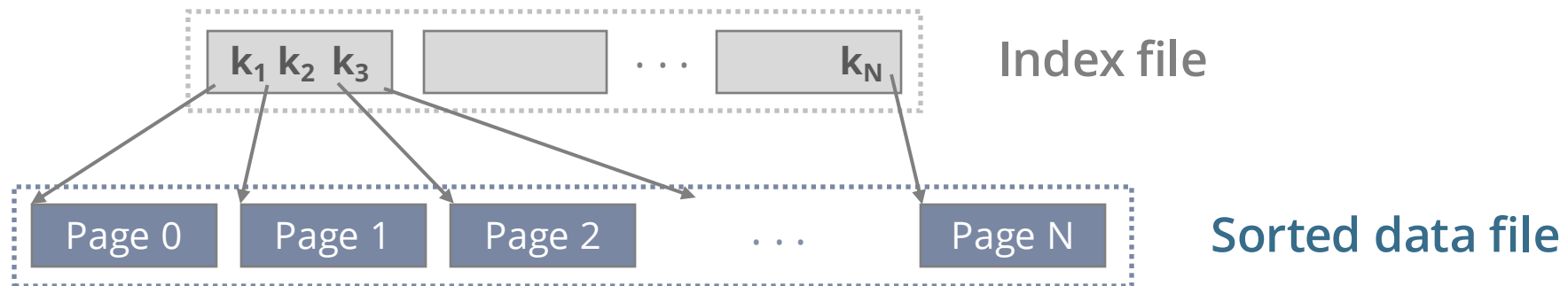

Can do binary search on (smaller) index file!

TREE-STRUCTURED INDEXING

Size of index is likely much smaller than size of data

Searching the index file is far **more efficient** than searching the data file

Index file may still be quite large \Rightarrow **apply the idea repeatedly!**

Treat the topmost index level as data file

Add an index level on top of that

Repeat until the topmost index level fits on one page

The topmost level is called the **root** page

ISAM: INDEXED SEQUENTIAL ACCESS METHOD

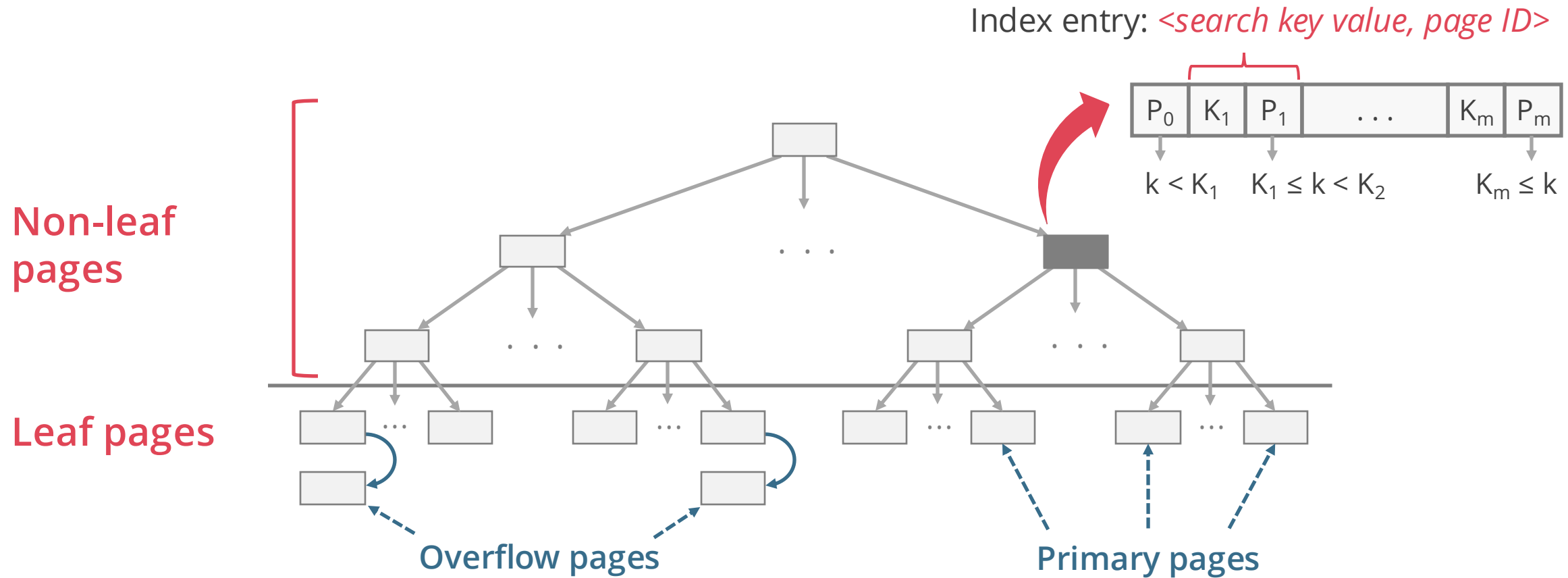

Non-leaf pages only direct searches

Leaf pages contain sorted index data entries k^* (e.g., $\langle k, \text{rid} \rangle$)

ISAM: INDEXED SEQUENTIAL ACCESS METHOD

Leaf (data) pages allocated **sequentially**, sorted by search key

No need to link leaf pages together

Search: Start at root, use key comparisons to go to leaf

Insert: Find the leaf where record belongs to

Insert record there if enough space

Otherwise, create an overflow page hanging off the primary leaf page

Delete: Find and remove record from its leaf

If an overflow page becomes empty, deallocate it

Static tree structure: inserts/deletes affect only leaf pages

EXAMPLE ISAM TREE

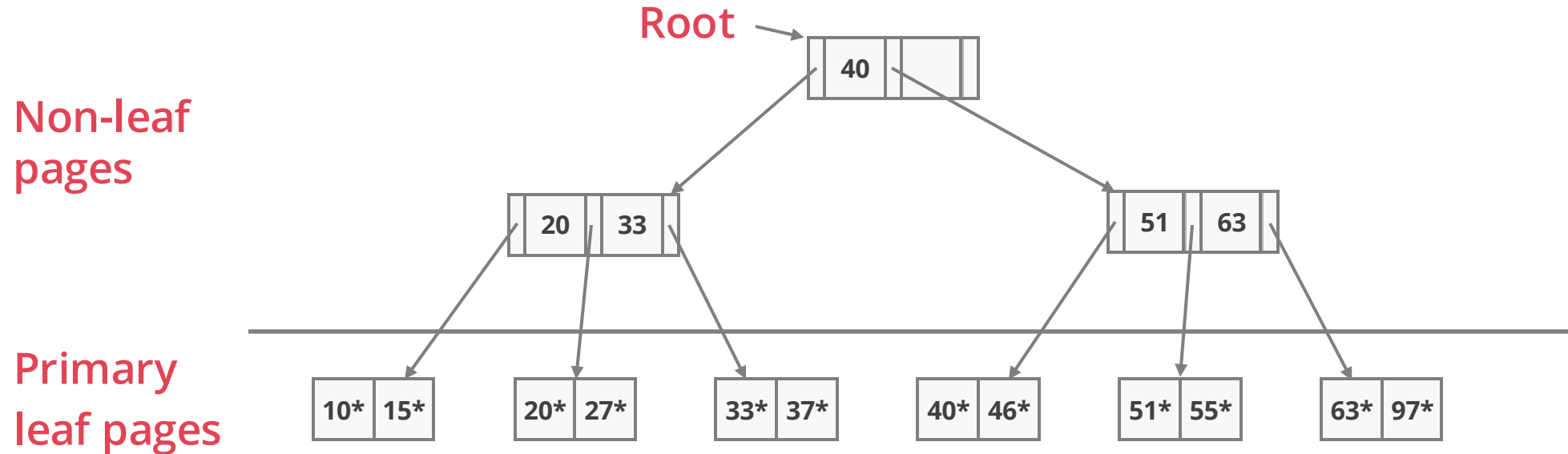

Each node can hold two index entries plus one page pointer (the left-most one)

AFTER INSERTING 23*, 48*, 41*, 42*...

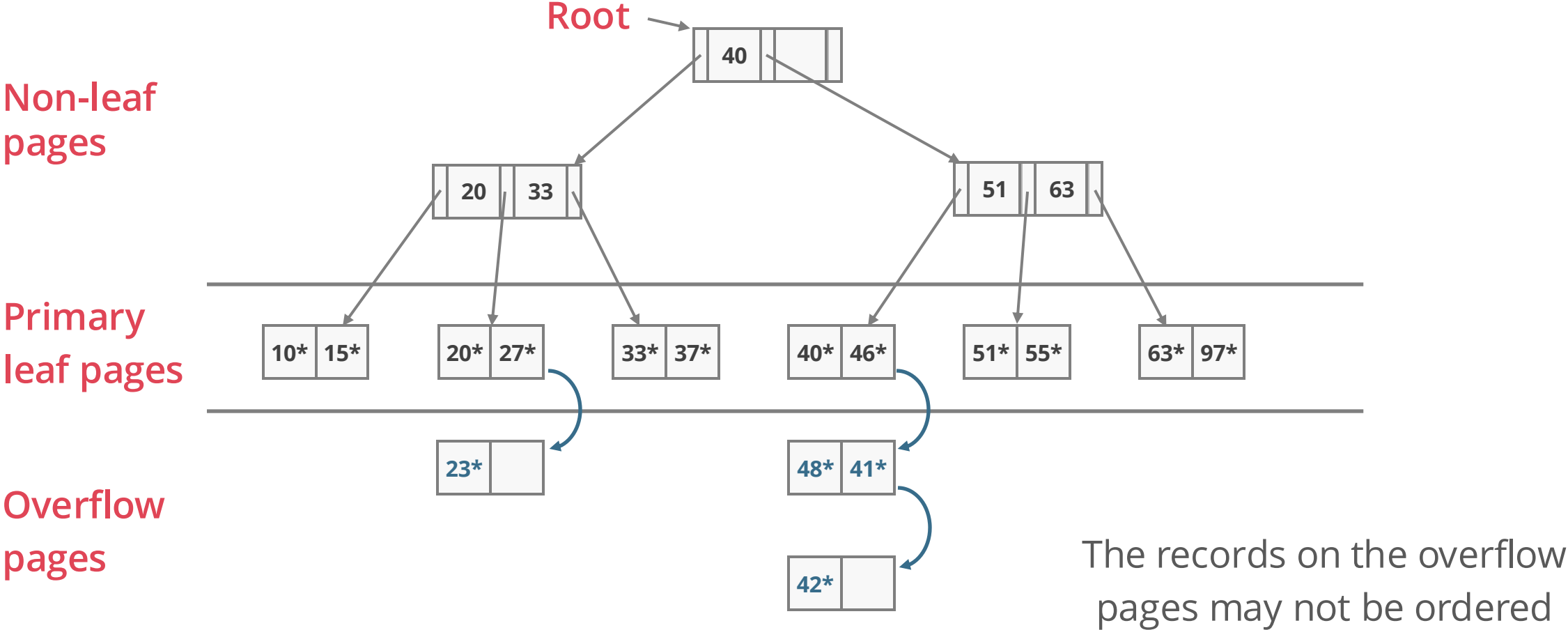

... THEN DELETING 42*, 97*, 51*

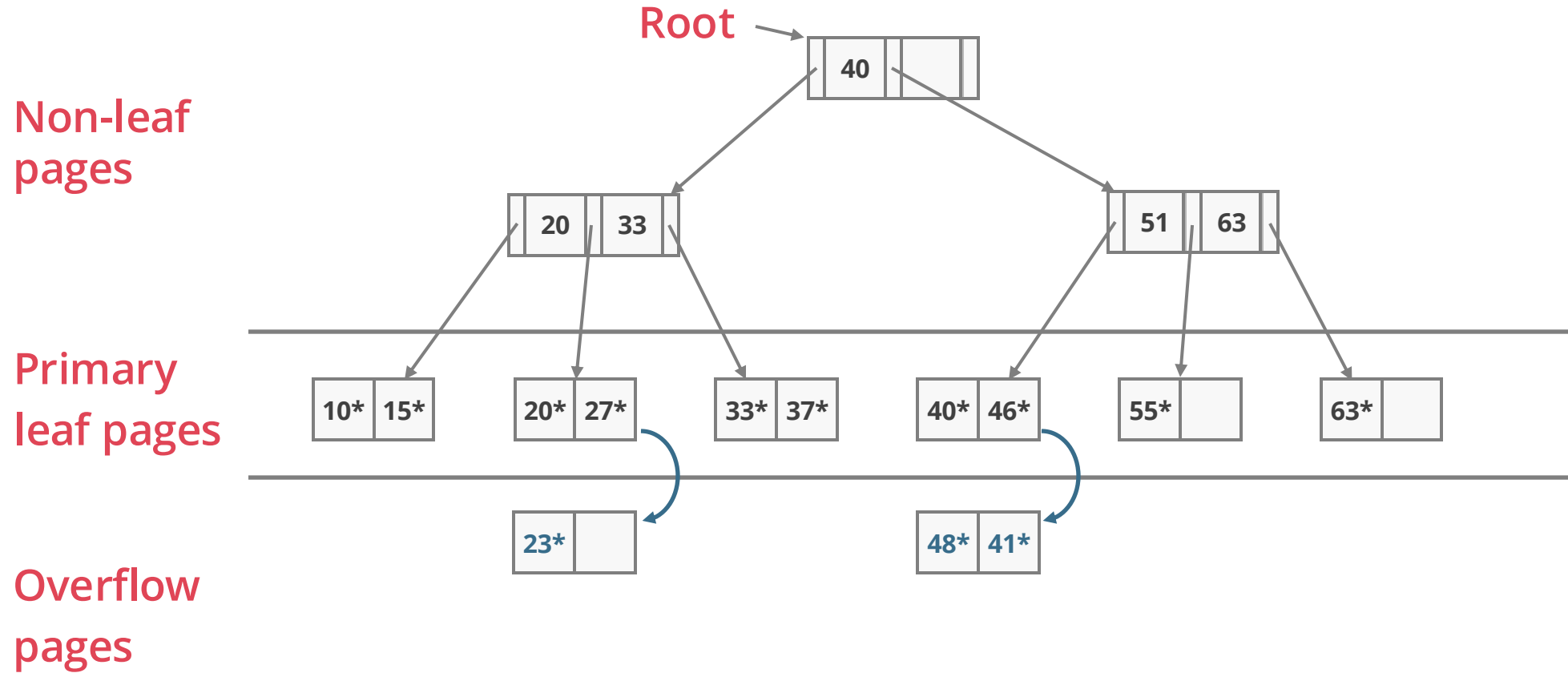

Note that 51 appears in index levels, but not in leaf!

COMMENTS ON ISAM

Non-leaf levels are not affected by inserts/deletes

Need **not** be locked during concurrent index accesses

Locking can be a bottleneck in dynamic tree indexes (particularly near the root)

ISAM may **lose balance** after heavy updating

Creating long chains of (unsorted) overflow pages

Search performance can degrade over time

Leaving free space (~20%) during index creation partially reduces this problem

ISAM may be the index of choice for relatively static data

ISAM vs. BINARY SEARCH

N = number of pages in the data file (search space)

Fanout F = max #children / index node

$F = 3$ in the previous example; $F = 1000$ typically

From the root page we are guided into an index subtree of size N / F

After s steps down the tree, the search space is reduced to $N \cdot (1 / F)^s$

Assume we reach a leaf node after s steps

$N \cdot (1 / F)^s = 1$ hence $s = \log_F(N)$

$F \gg 2$, hence $\log_F(N) \ll \log_2(N)$

**ISAM is much more efficient
than binary search!**

B+ TREE: MOST WIDELY USED INDEX

B+ tree is like ISAM but

Has no overflow chains, it remains always balanced

I.e., every leaf is at same depth

Search performance only dependent on the height

Because of high fanout F , the height rarely exceeds 3

Offers efficient insert/delete procedures

The data file can grow/shrink dynamically, non-leaf nodes are modified

Each node (except the root) has a **minimum occupancy** of 50%

Each non-root node contains $d \leq m \leq 2d$ entries, d is called the **order** of the tree

EXAMPLE B+ TREE

B+ tree of order $d = 2$

Note that leaf pages are doubly linked

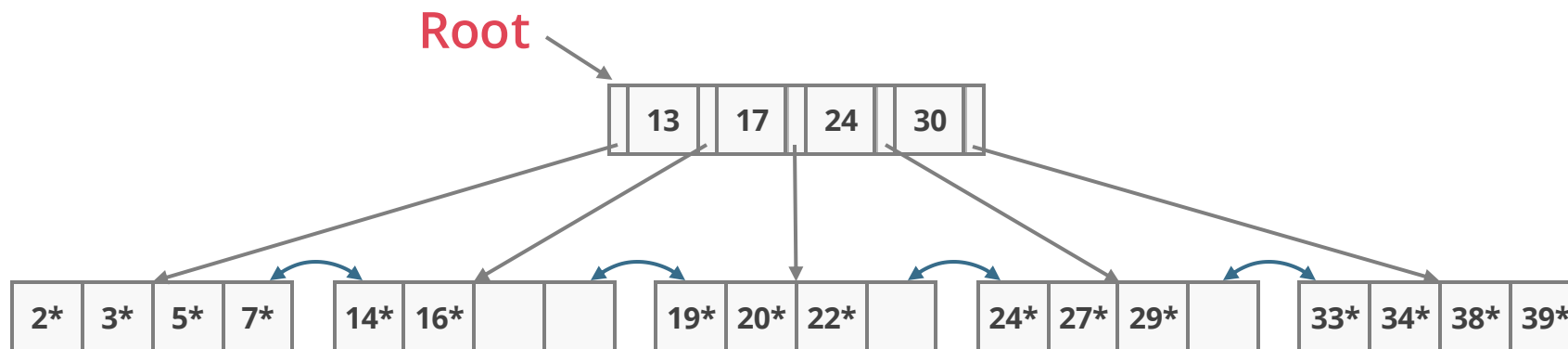

Occupancy Invariant:

Each non-root node is at least partially full: $d \leq \#entries \leq 2d$

Max fan-out = $2d + 1$

Data pages at bottom need not be stored in sequential order

Leaf pages allocated dynamically, linked via next and prev pointers

EXAMPLE B+ TREE

B+ tree of order $d = 2$

Note that leaf pages are doubly linked

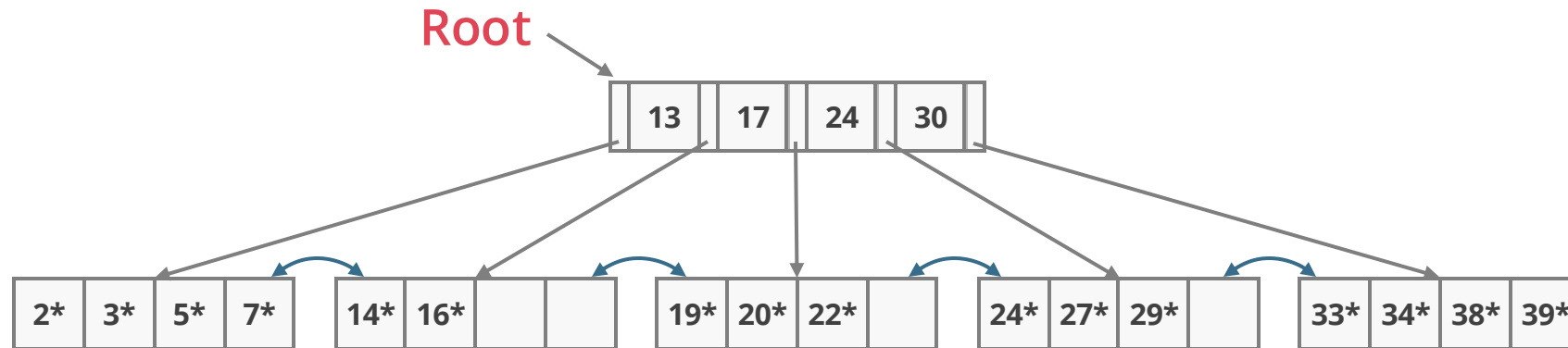

Search begins at root, and key comparisons direct it to a leaf (as in ISAM)

Search for 5*, 15*, all data entries $\geq 24^*$...

Based on the search for 15*, we know it is not in the tree!

B+ TREES IN PRACTICE

Typical order: 100. Typical fill-factor: 67%

Average fanout $F = 2 * 100 * 0.67 = 133$

Typical capacities

Height 4: $133^4 = 312,900,721$ records

Height 3: $133^3 = 2,352,637$ records

Can often hold top levels in buffer pools

Level 1 = 1 page = 8KB

Level 2 = 133 pages = 1MB

Level 3 = 17,689 pages = 138MB

INSERTING A DATA ENTRY

Find correct leaf **L**

Put data entry into **L** in sorted order

If **L** has enough space, done!

Else, must split **L** into **L** and a new node **L2**

Redistribute entries evenly, **copy up** middle key

Insert index entry pointing to **L2** into parent of **L**

To split inner node, redistribute entries evenly, but **push up** middle key

INSERTING 8* INTO EXAMPLE B+ TREE

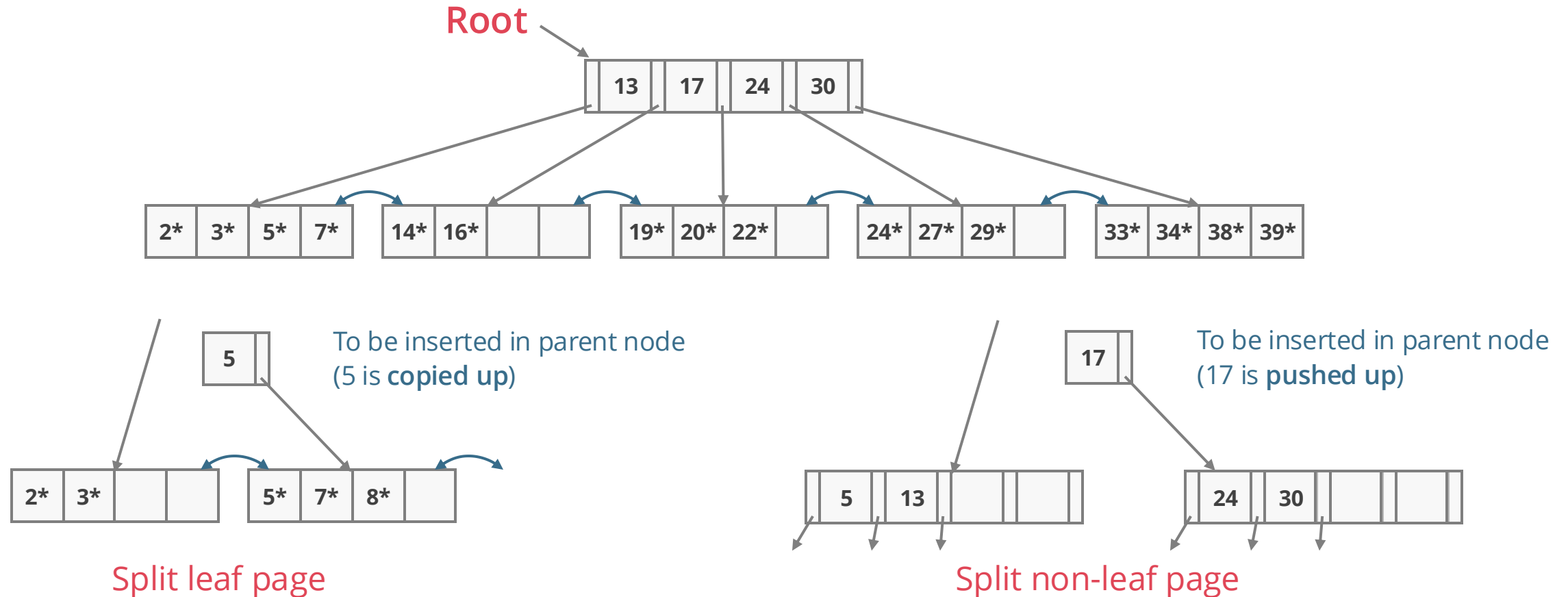

Observe how minimum occupancy is guaranteed in both leaf and non-leaf page splits
 Note difference between **copy-up** and **push-up**; be sure you understand the reasons for this

EXAMPLE B+ TREE AFTER INSERTING 8*

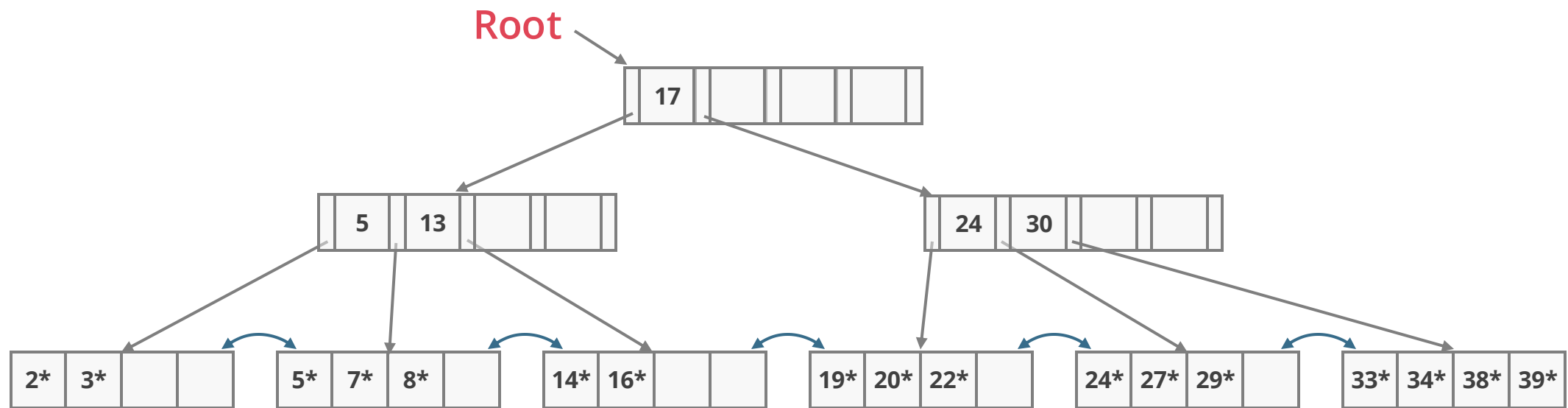

Notice that root was split, leading to increase in height

In this example, we can avoid split by **re-distributing** entries

REDISTRIBUTION: INSERTING 6*

Move keys to under-filled sibling pages and adjust separator

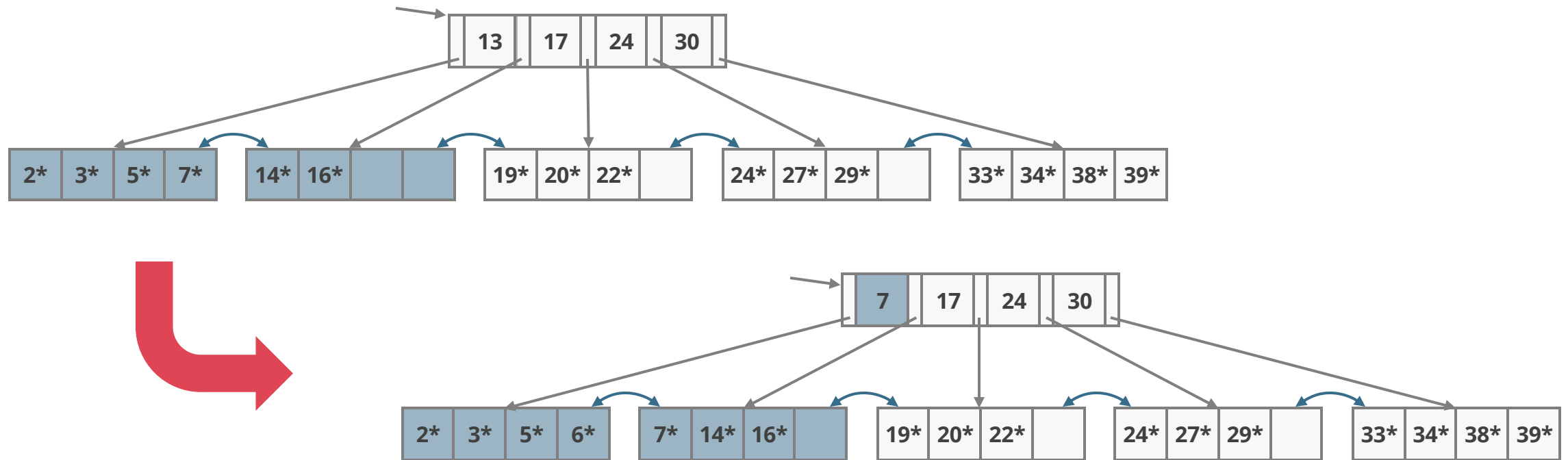

Adds additional I/O, but more efficient space use

In practice, redistribution is done only at leaf level (pointers provide direct access to siblings!)

DELETING A DATA ENTRY FROM A B+ TREE

Start at root, find leaf **L** where entry belongs

Remove the entry

If **L** is at least half-full, done!

If **L** has only $d-1$ entries,

Try to **redistribute**, borrowing from sibling (adjacent node with same parent as **L**)

If redistribution fails, **merge** **L** and sibling

If merge occurred, must delete entry (pointing to **L** or sibling) from parent of **L**

Merge could propagate to root, decreasing height

DELETING 19* AND 20*...

Deleting 19* is easy

no underflow since p remains
with $d = 2$ entries

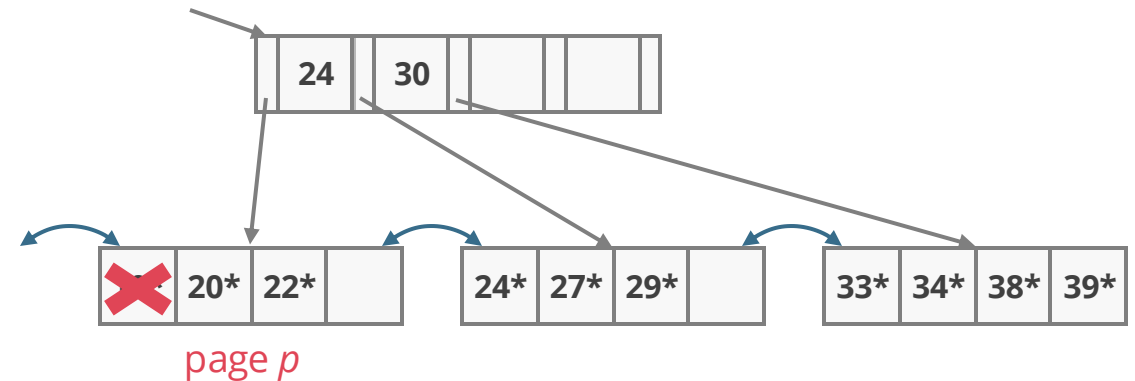

Deleting 20*

p underflow and p' has $> d$ entries
⇒ **(leaf node) redistribution**

Notice how middle key is **copied up**

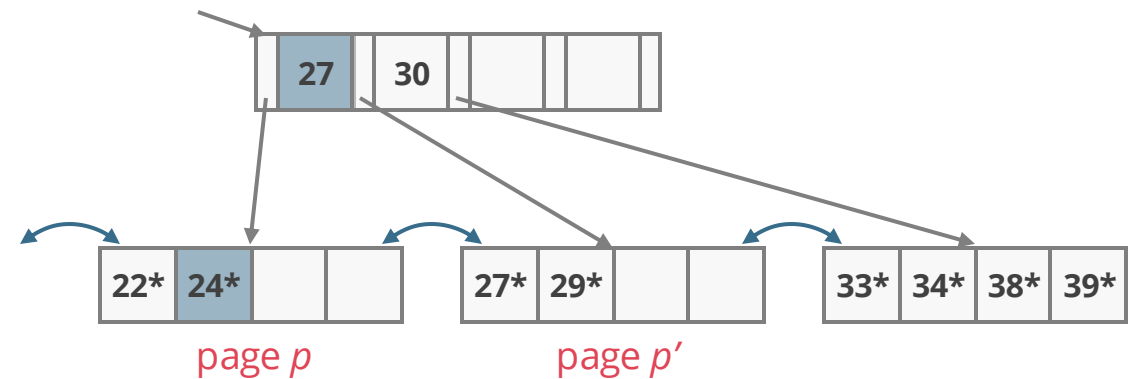

... AND THEN DELETING 24*

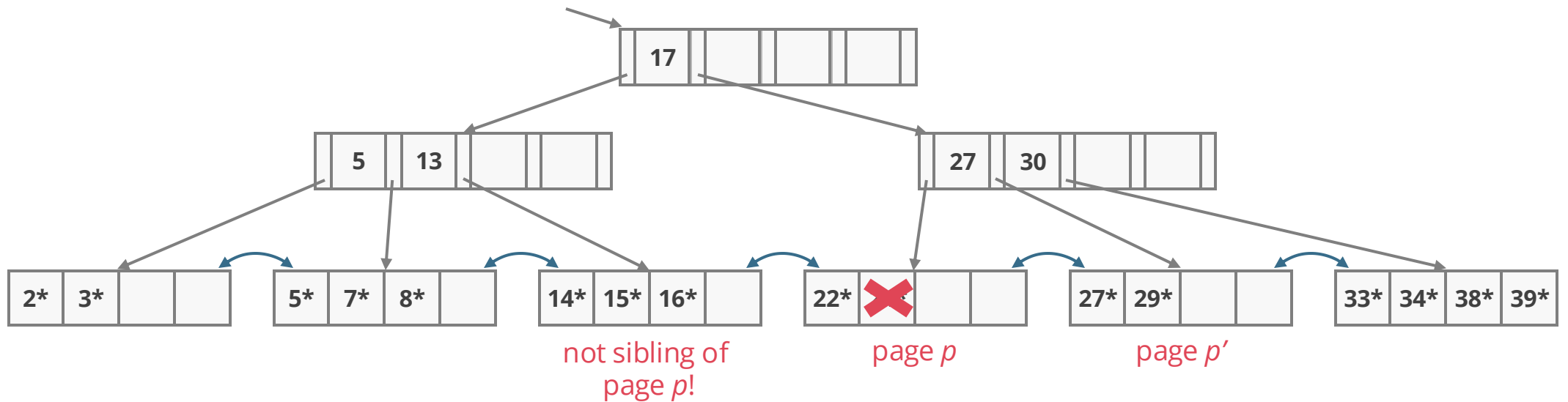

p underflow and p' has $d = 2$ entries

⇒ (leaf node) merge

Delete separator between p and p' (27) recursively

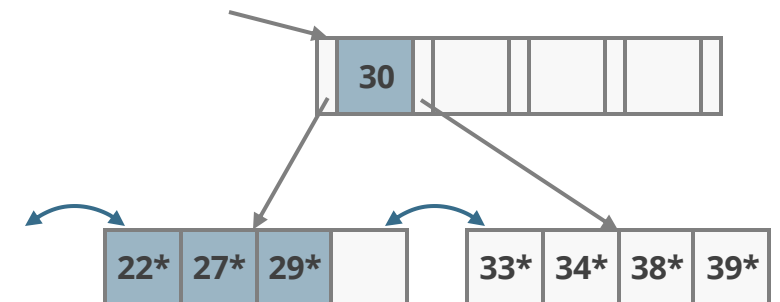

... STILL DELETING 24* (MERGE)

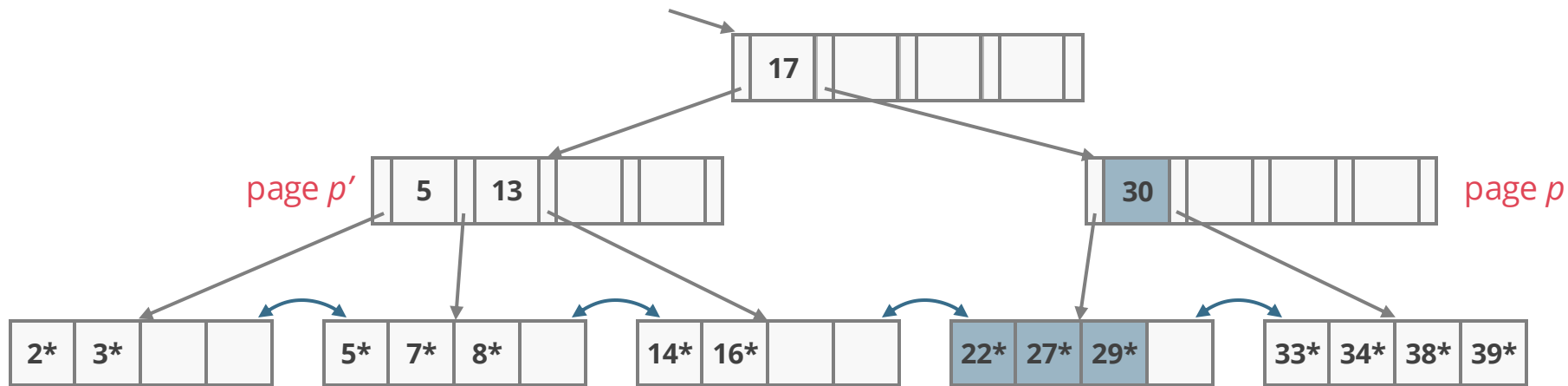

Delete 27 separator

p underflow and p' has $d = 2$ entries

⇒ **(non-leaf node) merge**

Merge p and p' by “pulling down” the separator

Since root is empty, delete it

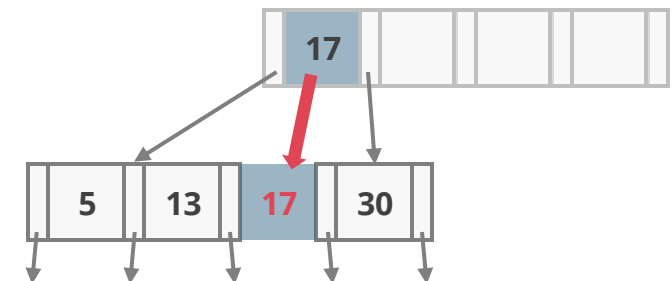

... STILL DELETING 24* (REDISTRIBUTION)

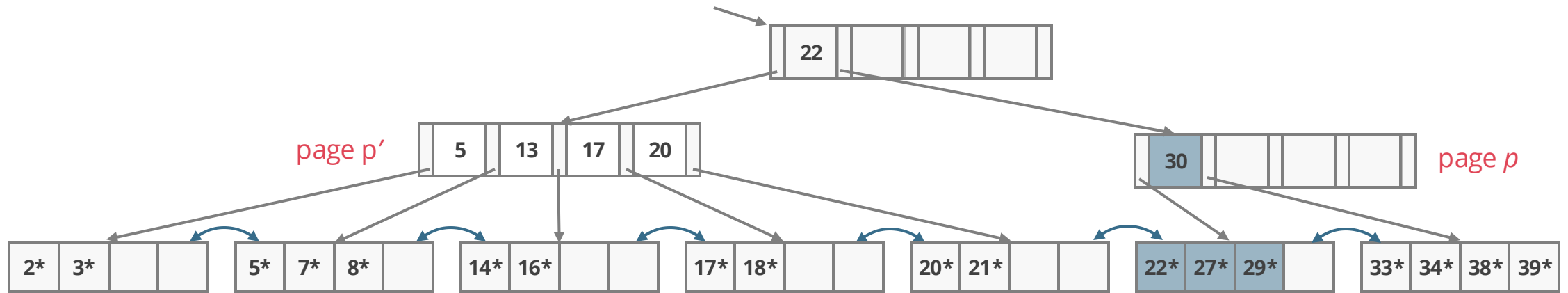

Assume a different left subtree

p underflow and p' has $> d = 2$ entries
 \Rightarrow **(non-leaf node) redistribution**

Redistribute entries by **'pushing through'**
 the splitting entry in the parent

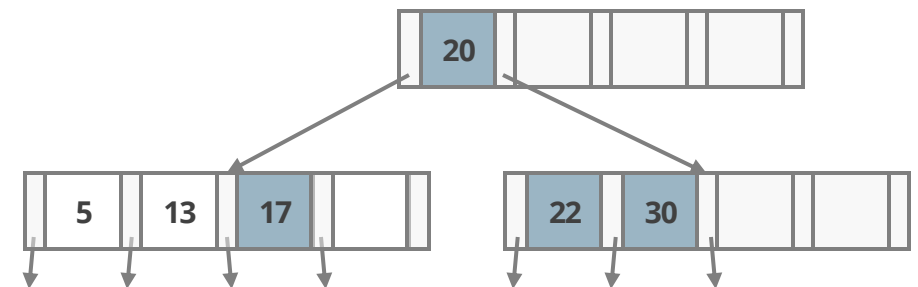

B+ TREE: DELETIONS

In practice, occupancy invariant often not enforced

Just delete leaf entries and leave space

If new inserts come, great

This is common

If page becomes completely empty, can delete

Parent may become underflow

That's OK too

Guarantees still attractive: $\log_F(\text{max size of tree})$

VARIABLE LENGTH KEYS & RECORDS

So far we have been using integer keys

5	13	17	20	
---	----	----	----	--

What would happen to our occupancy invariant with variable length keys?

robbed	robbing	robot	
--------	---------	-------	--

What about data in leaf pages stored using Variant **C**?

robbed: {3, 14, 30, 50, 75, 90}	robbing: {1}	robot: {12, 13}
---------------------------------	--------------	-----------------

REDEFINE OCCUPANCY INVARIANT

Order (d) makes little sense with variable-length entries

- Different nodes have different numbers of entries

- Non-leaf index pages often hold many **more entries** than leaf pages

- Even with fixed length fields, Variant **C** gives variable length data entries

Use a physical criterion in practice: **at-least half-full**

- Measured in **bytes**

Many real systems are even sloppier than this

- Only reclaim space when a page is completely empty

- Basically the deletion policy we described above...

OPTIMIZATIONS

Prefix compression

Sorted keys in the same leaf node are likely to have the same prefix

Instead of storing entire keys, extract common prefix and store only unique suffix for each key

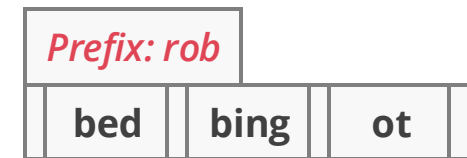

Suffix truncation

The keys in the inner nodes are only used to "direct traffic". We do not need the entire key

Store a minimum prefix needed to correctly route probes into the index

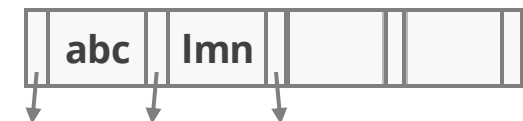

SUMMARY

ISAM and B+ tree support both **range searches** and **equality searches**

ISAM suitable for mostly static data

B+ tree is always a good choice

Great B+ tree visualisation:

<https://www.cs.usfca.edu/~galles/visualization/BPlusTree.html>