

# Informatics 2D: Reasoning and Agents

Slides provided by Prof. Alex Lascarides

Lecture 19: Planning and Acting in the Real World II

## Where are we?

Last time ...

- Looked at methods for real-world planning
- Sensorless planning and contingent planning
- Fully and partially observable environments

Today ...

- **Planning and Acting in the Real World II**

## Execution monitoring and replanning

- **Execution monitoring** = checking whether things are going according to plan (necessitated by unbounded indeterminacy in realistic environments)
  - Action monitoring = checking whether next action is feasible
  - Plan monitoring = checking whether remainder of plan is feasible
- **Replanning** = ability to find new plan when things go wrong (usually repairing the old plan)
- Taken together these methods yield powerful planning abilities

## Action monitoring and replanning

- While attempting to get from  $S$  to  $G$ , a problem is encountered in  $E$ , agent discovers actual state is  $O$  and plans to get to  $P$  and execute the rest of the original plan

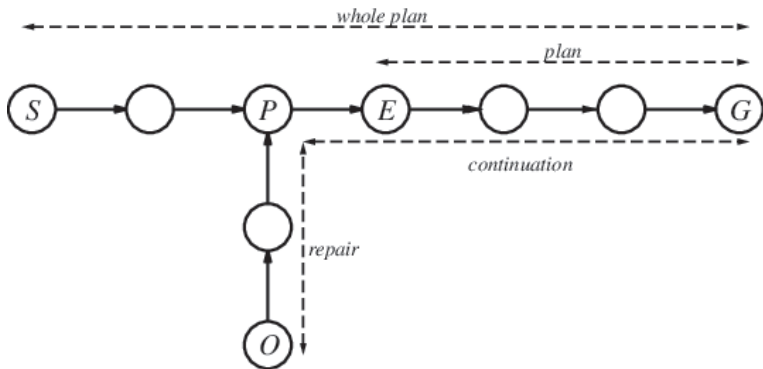

## Plan monitoring

- Action monitoring often results in suboptimal behaviour, executes everything until actual failure
- **Plan monitoring** checks preconditions for entire remaining plan
- Can also take advantage of **serendipity** (unexpected circumstances might make remaining plan easier)
- In partially observable environments things are more complex (sensing actions have to be planned for, they can fail in turn, etc.)

# Hierarchical decomposition in planning

- **Hierarchical decomposition** seems a natural idea to improve planning capabilities.
- **Key idea:** at each level of the hierarchy, activity involves only small number of steps (i.e. small computational cost)
- **Hierarchical task network (HTN) planning:** initial plan provides only high-level description, refined by **action refinements**
- Refinement process continued until plan consists only of **primitive actions**

# Representing action decompositions

- Each **high level action (HLA)** has (at least) one **refinement** into a sequence of actions.
- The actions in the sequence may be HLAs or primitive.
  - So HLAs form a hierarchy!
- If they're all primitive, then that's an **implementation** of the HLA.

## Example: Go to SF Airport

*Refinement*(*Go*(*Home*, *SFO*),

Precond:*At*(*Car*, *Home*)

Steps:[*Drive*(*Home*, *SFO**LongTermParking*)

*Shuttle*(*SFO**LongTermParking*, *SFO*)]])

*Refinement*(*Go*(*Home*, *SFO*),

Precond:*Cash*, *At*(*Home*)

Steps:[*Taxi*(*Home*, *SFO*)]])

## Refinements can be Recursive

*Refinement(Navigate([a, b], [x, y]),*

Precond:  $a = x, b = y$

Steps: [])

*Refinement(Navigate([a, b], [x, y]),*

Precond: *Connected*([a, b], [a - 1, b])

Steps: [*Left*, *Navigate*([a - 1, b], [x, y])])

*Refinement(Navigate([a, b], [x, y]),*

Precond: *Connected*([a, b], [a + 1, b])

Steps: [*Right*, *Navigate*([a + 1, b], [x, y])])

# High-Level Plans

- High-Level Plans (HLP) are a sequence of HLAs.
- An implementation of a High Level Plan is the concatenation of an implementation of each of its HLAs.
- A HLP achieves the goal from an initial state if **at least one** of its implementations does this.
- **Not all implementations of an HLP have to reach the goal state!**
- The agent gets to decide which implementation of which HLAs to execute.

## Searching for Primitive Solutions

- The **HLA plan library** is a **hierarchy**:
  - (Ordered) Daughters to an HLA are the sequences of actions provided by one of its refinements;
  - Because a given HLA can have more than one refinement, there can be more than one node for a given HLA in the hierarchy.
- This hierarchy is essentially a **search space of action sequences** that conform to knowledge about how high-level actions can be broken down.
- So you can search this space for a plan!

## Searching for Primitive Solutions: Breadth First

- Start your plan  $P$  with the HLA [Act],
- Take the first HLA  $A$  in  $P$  (recall that  $P$  is an *action sequence*).
- Do a breadth-first search in your hierarchical plan library, to find a refinement of  $A$  whose preconditions are satisfied by the outcome of the action in  $P$  that is prior to  $A$ .
- Replace  $A$  in  $P$  with this refinement.
- Keep going until your plan  $P$  has no HLAs and either:
  - 1 Your plan  $P$ 's outcome is the goal, in which case return  $P$ ; or
  - 2 Your plan  $P$ 's outcome is not the goal, in which case backtrack, and if nowhere to backtrack then return *failure*.

## Problems!

- Like forward search, you consider lots of irrelevant actions.
- The algorithm essentially refines HLAs right down to primitive actions so as to determine if a plan will succeed.
- This contradicts **common sense!**
- Sometimes you know an HLA will work *regardless* of how it's broken down!
- We don't need to know which route to take to SFOParking to know this plan works:

$[Drive(Home, SFOParking), Shuttle(SFOParking, SFO)]$

- We can capture this if we add to HLAs *themselves* a set of preconditions and effects.

## Adding Preconditions and Effects to HLAs

- One challenge in specifying preconditions and effects of an HLA is that the HLA may have more than one refinement, each one with slightly different preconditions and effects!
  - If you refine *Go(Home, SFO)* with *Taxi* action: you need *Cash*.
  - If you refine it with *Drive*, you don't!
  - This difference may affect your **choice** on how to refine the HLA!
- Recall that an HLA achieves a goal if **one** of its refinements does this.
- **And you can choose the refinement!**

## Getting Formal

- $s' \in \text{Reach}(s, h)$  iff  $s'$  is reachable from *at least one* of HLA  $h$ 's refinements, given (initial) state  $s$ .

$$\text{Reach}(s, [h_1, h_2]) = \bigcup_{s' \in \text{Reach}(s, h_1)} \text{Reach}(s', h_2)$$

- HLP  $p$  achieves goal  $g$  given initial state  $s$  iff  $\exists s'$  st

$$s' \models g \text{ and } s' \in \text{Reach}(s, p)$$

- So we should search HLPs to find a  $p$  with this relation to  $g$ , and then focus on refining it.
- But a pre-requisite to this algorithm is to define  $\text{Reach}(s, h)$  for each  $h$  and  $s$ .
- In other words, we still need to determine how to represent effects (and preconditions) of HLAs...

## Defining Reach

- A primitive action makes a fluent true, false, or leaves it unchanged.
- But with HLAs you sometimes get to *choose*, by choosing a particular refinement!
- We add new notation to reflect this:
  - $\tilde{+}A$ : you can possibly add  $A$  (or leave  $A$  unchanged)
  - $\tilde{-}A$ : you can possibly delete  $A$  (or leave  $A$  unchanged)
  - $\tilde{\pm}A$ : you can possibly add  $A$ , or possibly delete  $A$  (or leave  $A$  unchanged)
- You should now *derive* the correct preconditions and effects from its refinements!

## Our SFO Example

*Refinement*(*Go*(*Home*, *SFO*),  
Precond:*At*(*Car*, *Home*)  
Steps:[*Drive*(*Home*, *SFO**LongTermParking*)  
*Shuttle*(*SFO**LongTermParking*, *SFO*)]])

*Refinement*(*Go*(*Home*, *SFO*),  
Precond:*Cash*, *At*(*Home*)  
Steps:[*Taxi*(*Home*, *SFO*)]])

## The 'Primitive' Actions

*Action(Taxi(a, b),*

Precond: *Cash, At(Taxi, a)*

Effect:  $\neg$ *Cash,  $\neg$ At(Taxi, a), At(Taxi, b)*)

*Action(Drive(a, b),*

Precond: *At(Car, a)*

Effect:  $\neg$ *At(Car, a), At(Car, b)*)

*Action(Shuttle(a, b),*

Precond: *At(Shuttle, a)*

Effect:  $\neg$ *At(Shuttle, a), At(Shuttle, b)*)

## Deriving the Preconds and Effects of the HLA

- $\neg \text{Cash}$  is Effect of one HLA refinement, but not the other.
- So  $\sim \text{Cash}$  in HLA Effect!

### Not so Simple!

- Similar argument for  $\text{At}(\text{Car}, \text{SFOParking})$
- **But you can't choose the combination:**  
 $\neg \text{Cash} \wedge \text{At}(\text{Car}, \text{SFOParking})$
- Solution is to write **approximate descriptions.**

## Approximate Descriptions

### Optimistic Description: $\text{Reach}^+(s, h)$

- Take union of all possible outcomes from all refinements.
- So this includes  $\neg \text{Cash}$  and  $\tilde{+} \text{At}(\text{Car}, \text{SFOParking})$ .
- This overgenerates reachable states.

### Pessimistic Description: $\text{Reach}^-(s, h)$

- Only states that satisfy effects from *all* refinements survive.
- So this does *not* include  $\neg \text{Cash}$  or  $\tilde{+} \text{At}(\text{Car}, \text{SFOParking})$ .
- This undergenerates reachable states.

$$\text{Reach}^-(s, h) \subseteq \text{Reach}(s, h) \subseteq \text{Reach}^+(s, h)$$

## Algorithm for Finding a Plan

Two Important Facts:

- 1 If  $\exists s' \in \text{Reach}^-(s, h)$  st  $s' \models g$ , you know  $h$  can succeed.
- 2 If  $\neg \exists s' \in \text{Reach}^+(s, h)$  st  $s' \models g$ , you know  $h$  will fail!

The Algorithm:

- Do breadth first search as before.
- But now you can **stop searching** and **implement instead** when you reach an  $h$  where 1. is true.
- And you can **drop**  $h$  (and all its refinements) when 2. is true.
- If 1. and 2. are both false for the current  $h$ , then you don't know if  $h$  will succeed or fail, but you can find out by refining it.

## Summary

- Execution monitoring: checking success of execution
- Replanning: repairing plans in case of failure
- HLAs and HLPs
- Using refinements and preconditions and effects of primitive actions to *approximate* which states are reachable.
- Such approximate descriptions of HLAs help to inform search and when to refine an HLP so as to reach a goal.
- Next time: **Acting under Uncertainty**