



THE UNIVERSITY
of EDINBURGH

Advanced Database Systems

Spring 2024

Lecture #24:

Transactions

R&G: Chapters 16 & 17

ARCHITECTURE OF A DBMS

Up until now we have assumed a single-user architecture and failure-free execution

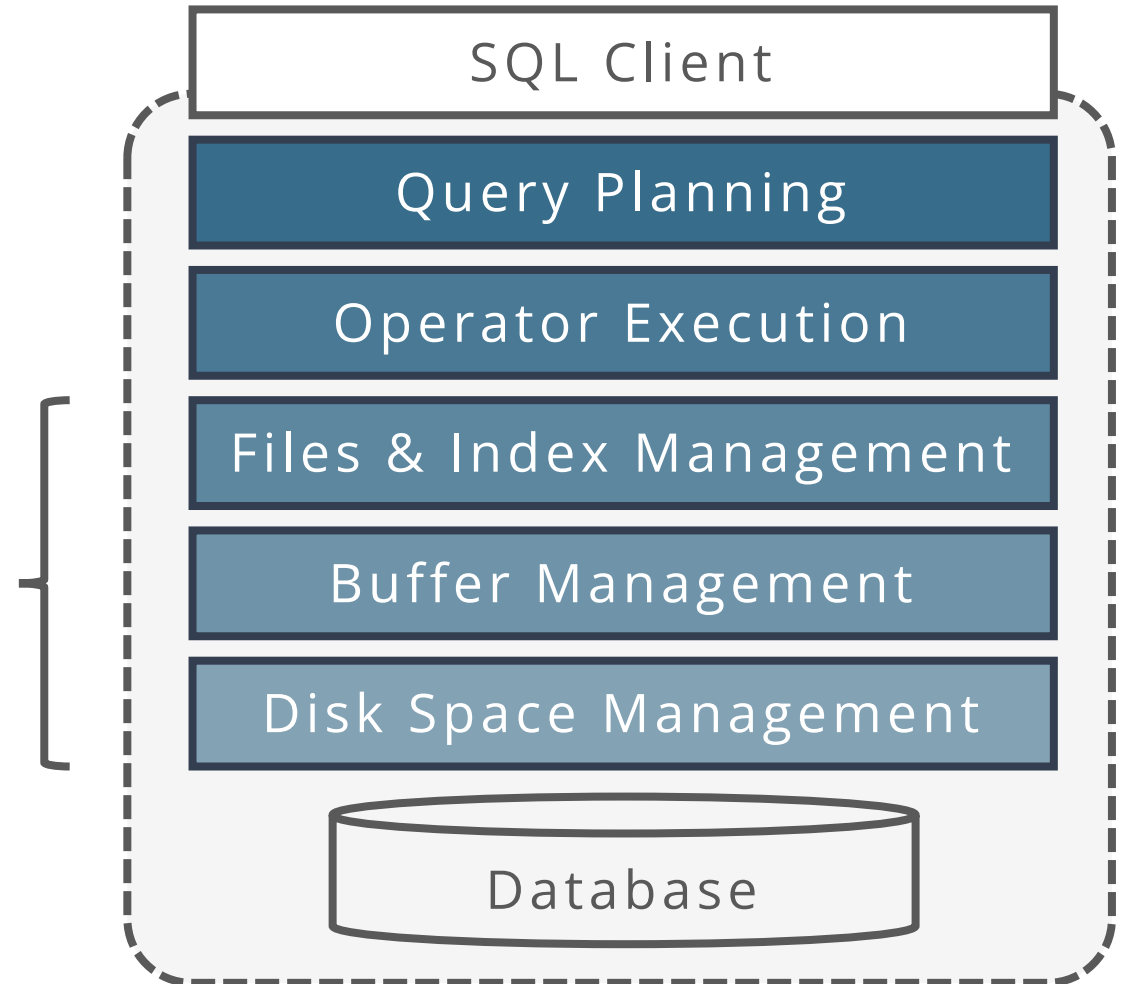

MOTIVATION

We both change the same record in a table at the same time.

How to avoid race condition?

You transfer £100 between bank accounts but there is a power failure.

What is the correct database state?



Concurrency Control



Recovery

Both concurrency control and recovery are based on a concept of transactions with **ACID** properties

TRANSACTIONS

A **transaction** is the execution of a sequence of operations (e.g., SQL queries) on a shared database to perform some higher-level function

Basic unit of change in a DBMS

Partial transactions are not allowed!

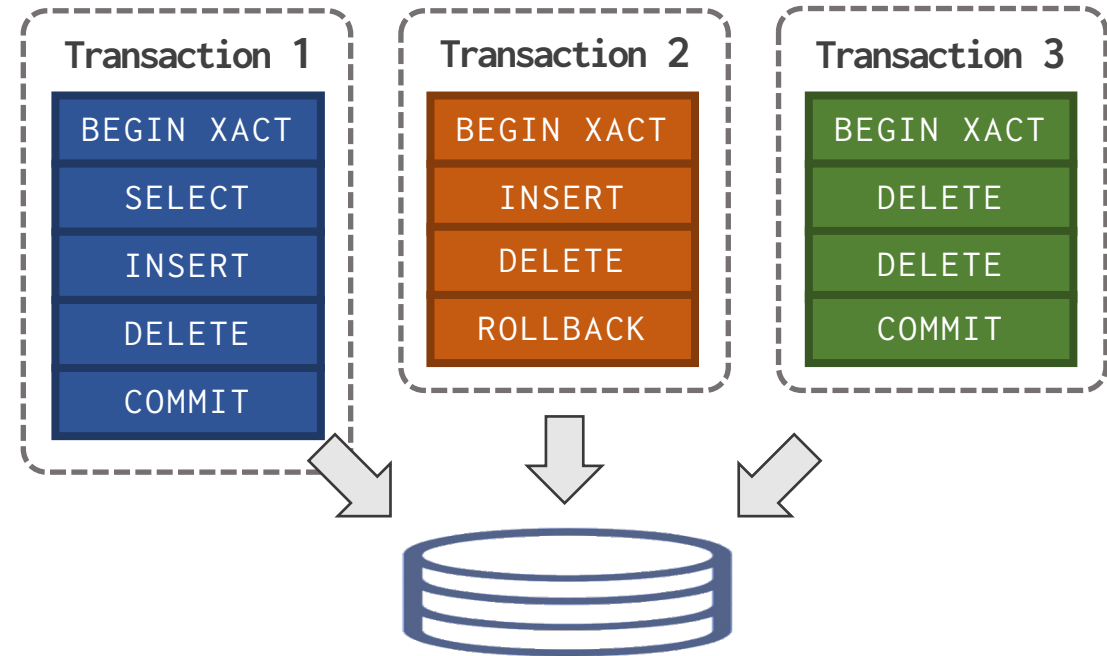

USER PERSPECTIVE: TRANSACTIONS

Transaction (abbr. txn) = **group of operations** the user wants the DBMS to treat “as one”

A new transaction starts with the **BEGIN** command

The transaction stops with either **COMMIT** or **ABORT (ROLLBACK)**

- If commits, all changes are saved

- If aborts, all changes are undone (as if the txn never executed at all)

- Abort can be either self-inflicted or caused by DBMS

TRANSACTION EXAMPLE

Transfer £100 from Checking to Savings account of user 1904

```
BEGIN
// check if Checking balance > 100
UPDATE Accounts
  SET balance = balance - 100
  WHERE customer_id = 1904
     AND account_type = 'Checking';
UPDATE Accounts
  SET balance = balance + 100
  WHERE customer_id = 1904
     AND account_type = 'Savings';
COMMIT
```

Consistent DB

Temporary inconsistent DB

Consistent DB

TRANSACTION EXAMPLE

Transfer £100 from Checking to Savings account of user 1904

```
BEGIN
  // check if Checking balance > 100
  UPDATE Accounts
    SET balance = balance - 100
  WHERE customer_id = 1904
    AND account_type = 'Checking';
  UPDATE Accounts
    SET balance = balance + 100
  WHERE customer_id = 1904
    AND account_type = 'Savings';
COMMIT
```

How to check if balance > 100?

Outside DBMS using another language

E.g., in Java or PHP code

Inside DBMS using **stored procedures**
expressed in PL/SQL or T-SQL

PL/SQL = SQL + procedural constructs such as
if-then-else, loops, variables, functions...

DATABASE PERSPECTIVE

A transaction may carry out many operations on the data retrieved from the database

However, the DBMS is only concerned about what data is read/written from/to the database

Changes to the “outside world” are beyond scope of the DBMS

TRANSACTIONS: FORMAL DEFINITION

Database = fixed set of named data objects (A, B, C, \dots)

Transactions access object A using read A and write A , for short $R(A)$ and $W(A)$

In a relational DBMS, an object can be an attribute, record, page, or table

Transaction = sequence of read and write operations

$T = \langle R(A), W(A), W(B), \dots \rangle$

DBMS's abstract view of a user program

STRAWMAN EXECUTION

Execute each txn **one-by-one** (serial order) as they arrive in the DBMS

One and only one txn can be running at the same time in the DBMS

Before a txn starts, **copy** the entire database to a new file and make all changes to that file

If the txn completes successfully, overwrite the original file with the new one

If the txn fails, just remove the dirty copy

SQLite executes transactions in serial order

CONCURRENT EXECUTION

A better approach is to allow **concurrent execution** of independent transactions

Why do we want that?

Better resource utilization and throughput (txns/sec)

Use the CPU while another txn is waiting for the disk

Multicore: Ideally, scale throughput in the # of CPUs

Decreased response times to users

One txn's latency need not be dependent on another unrelated txn

Or that's the hope

But we also would like **correctness** and **fairness**

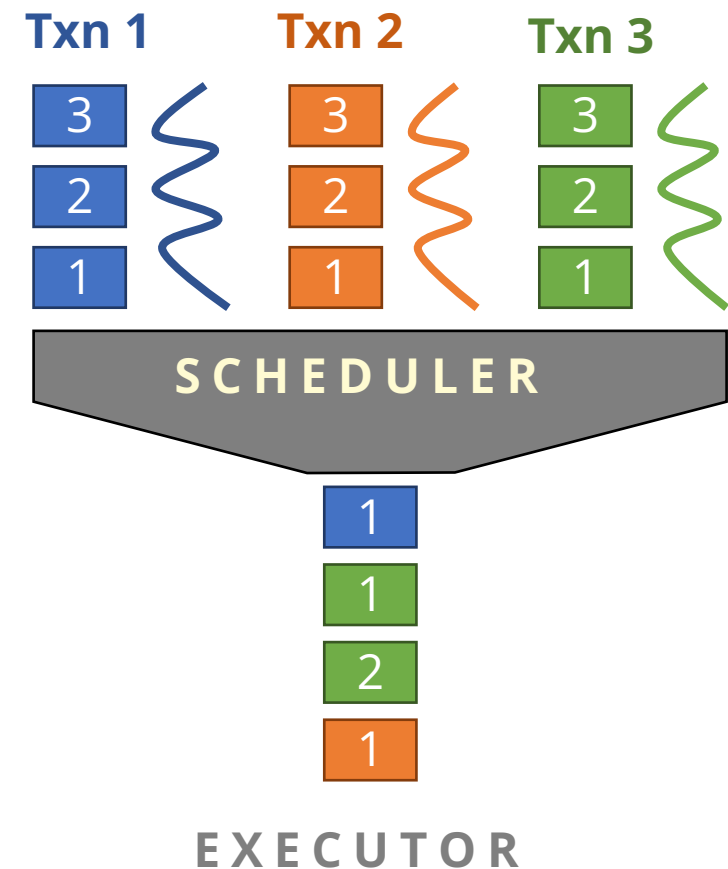

TRANSACTION GUARANTEES: ACID

Atomicity: *All* actions in the txn happen, or *none* happen

"all or nothing"

Consistency: If each txn is consistent and the DB *starts* consistent, then it *ends* up consistent

"it looks correct to me"

Isolation: Execution of one txn is isolated from that of other txns

"as if alone"

Durability: If a txn commits, its effects persist

"survive failures"

ACID PROPERTIES: ATOMICITY

Two possible outcomes of executing a transaction:

- Commit after completing all actions

- Abort (or be aborted by the DBMS) after executing some actions

The DBMS guarantees that transactions are **atomic**

- From user's point of view:

- A transaction always either executes all its actions or executes no actions at all

Example:

- Take £100 from account A, but then a power failure happens before crediting account B

- When the DBMS comes back online, what should be the correct state of the database?*

MECHANISMS FOR ENSURING ATOMICITY

Approach #1: Logging

DBMS logs all actions so that it can undo the actions of aborted transactions

Write-ahead logging is used by almost all modern database systems

Efficiency reasons: random writes turned into sequential writes through a log

Audit trail: everything done by the app is recorded

Approach #2: Shadow Paging (copy-on-write)

DBMS makes copies of pages and transactions make changes to those copies

Only when the transaction commits is the page made visible to others

Few database systems do this (CouchDB, LMDB)

ACID PROPERTIES: CONSISTENCY

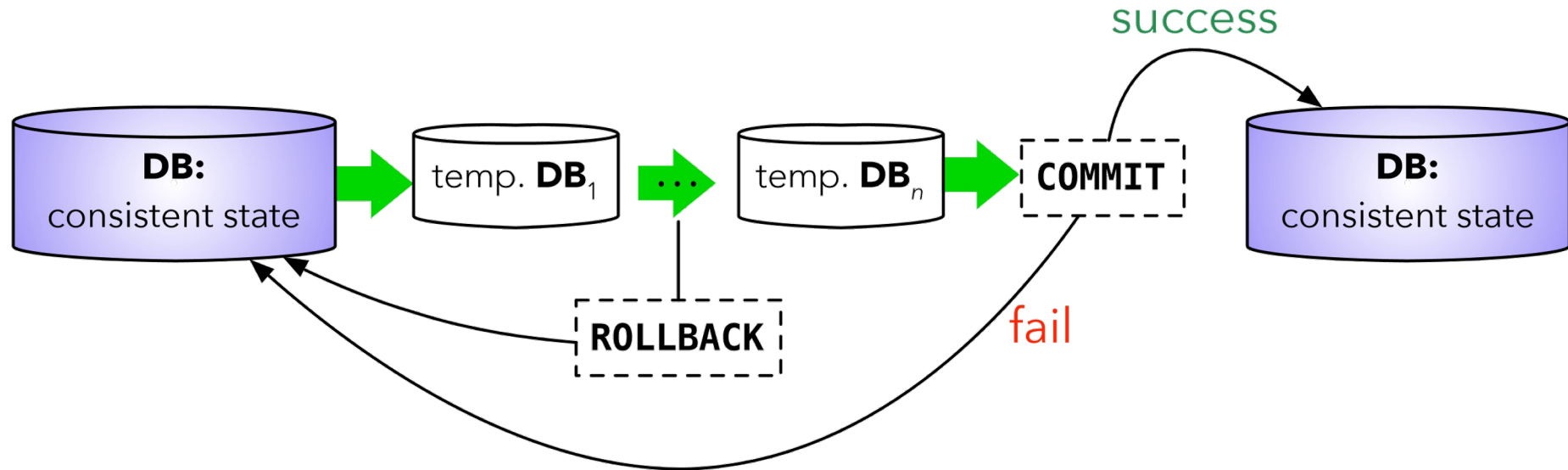

Database consistency

The database accurately models the real world and follows integrity constraints
Transactions in the future see the effects of transactions committed in the past

Transaction consistency

If the database is consistent before the txn starts (running alone), it will be also consistent after
Transaction consistency is the application's responsibility!

ACID PROPERTIES: ISOLATION

Users submit transactions, and each transaction executes as if it was running alone

The DBMS achieves concurrency by interleaving actions (read/writes of database objects) of various transactions

How do we achieve this?

MECHANISMS FOR ENSURING ISOLATION

A **concurrency control** protocol is how the DBMS decides the proper interleaving of operations from multiple transactions

Two main categories:

Pessimistic: Don't let problems arise in the first place

Optimistic: Assume conflicts are rare, deal with them after they happen

EXAMPLE

Assume at first accounts **A** and **B** each have £1000

T₁ transfers £100 from **A** to **B**

T₂ credits both accounts with 6% interest

T₁

BEGIN

$A = A - 100$

$B = B + 100$

END

T₂

BEGIN

$A = A * 1.06$

$B = B * 1.06$

END

EXAMPLE

Assume at first accounts **A** and **B** each have £1000

What are the possible outcomes of running T_1 and T_2 ?

Many! But **A+B** should be $2000 * 1.06 = 2120$

There is no guarantee that T_1 will execute before T_2 or vice versa, if both are submitted together

But the net effect must be equivalent to these two transactions running **serially** in some order

EXAMPLE: SERIAL EXECUTION

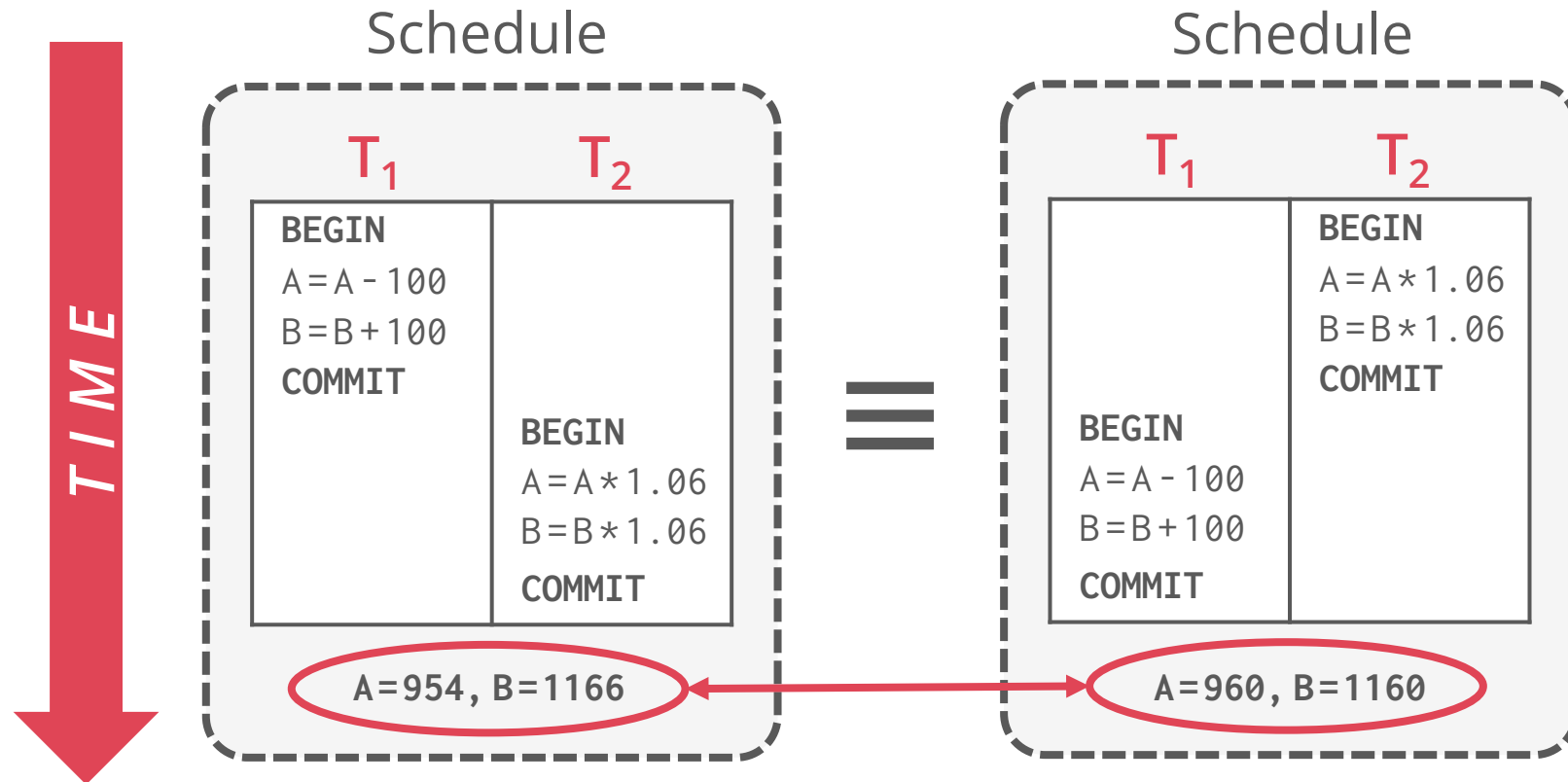

$$A+B = 2120$$

EXAMPLE: INTERLEAVING (GOOD)

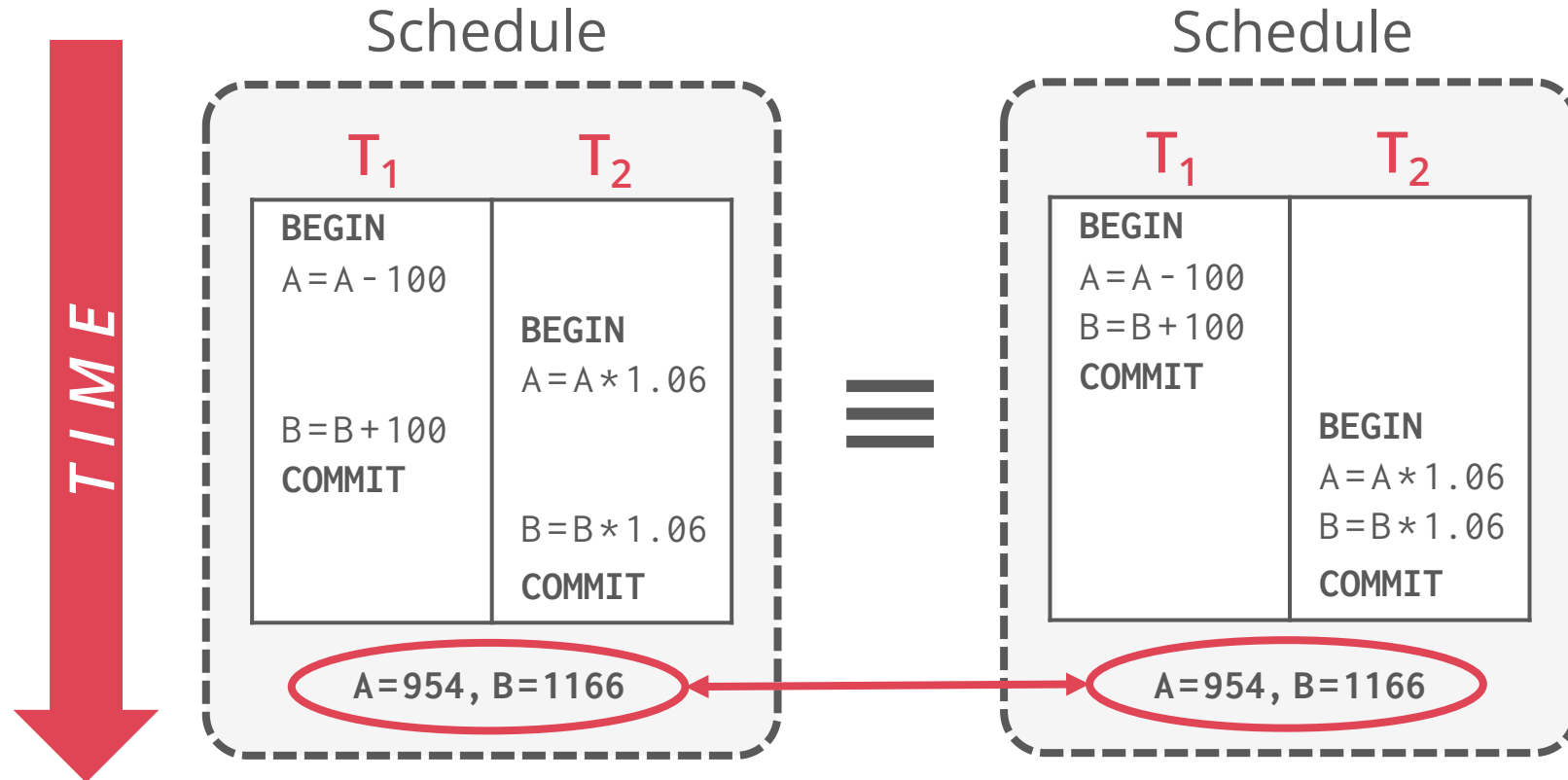

EXAMPLE: INTERLEAVING (BAD)

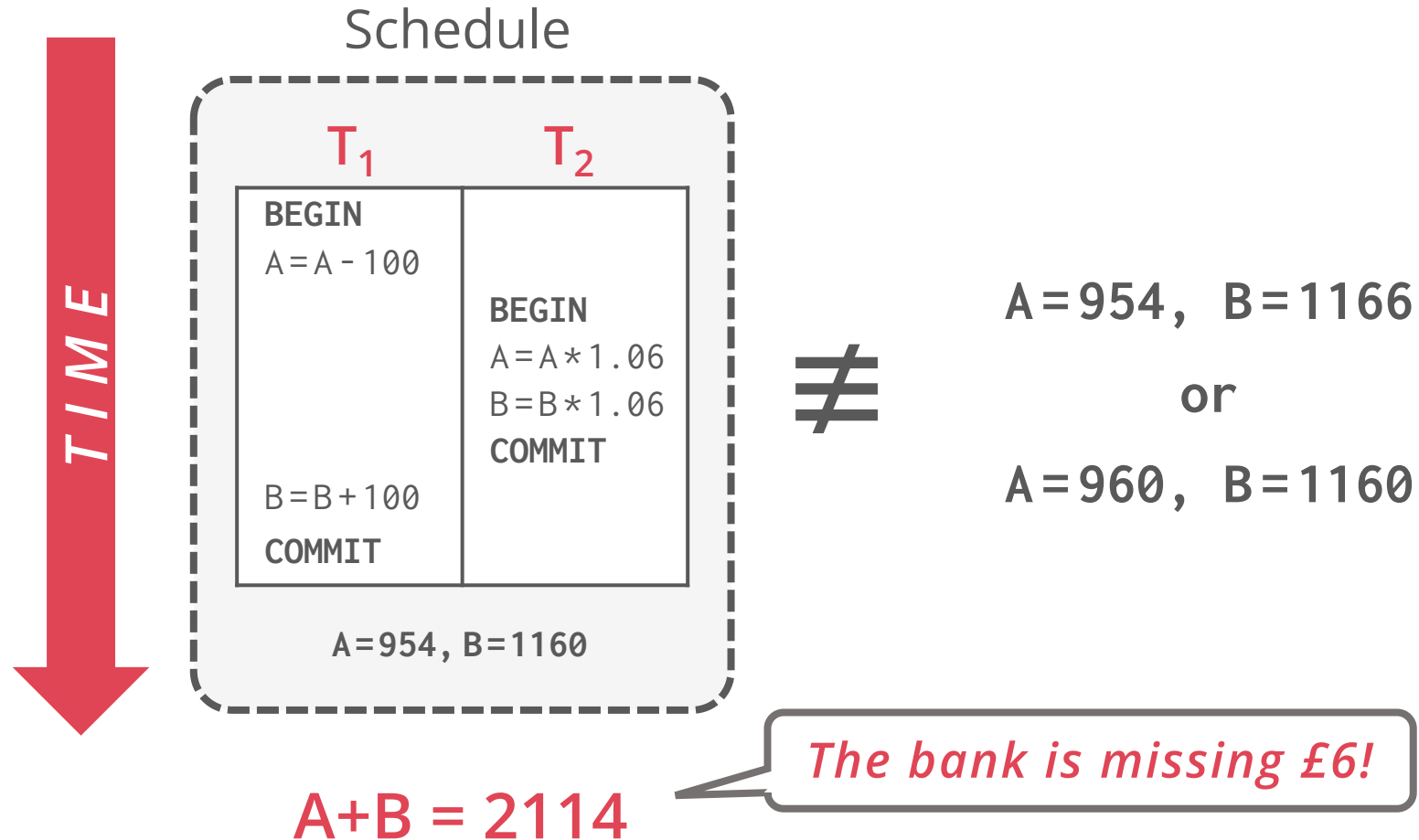

EXAMPLE: INTERLEAVING (BAD)

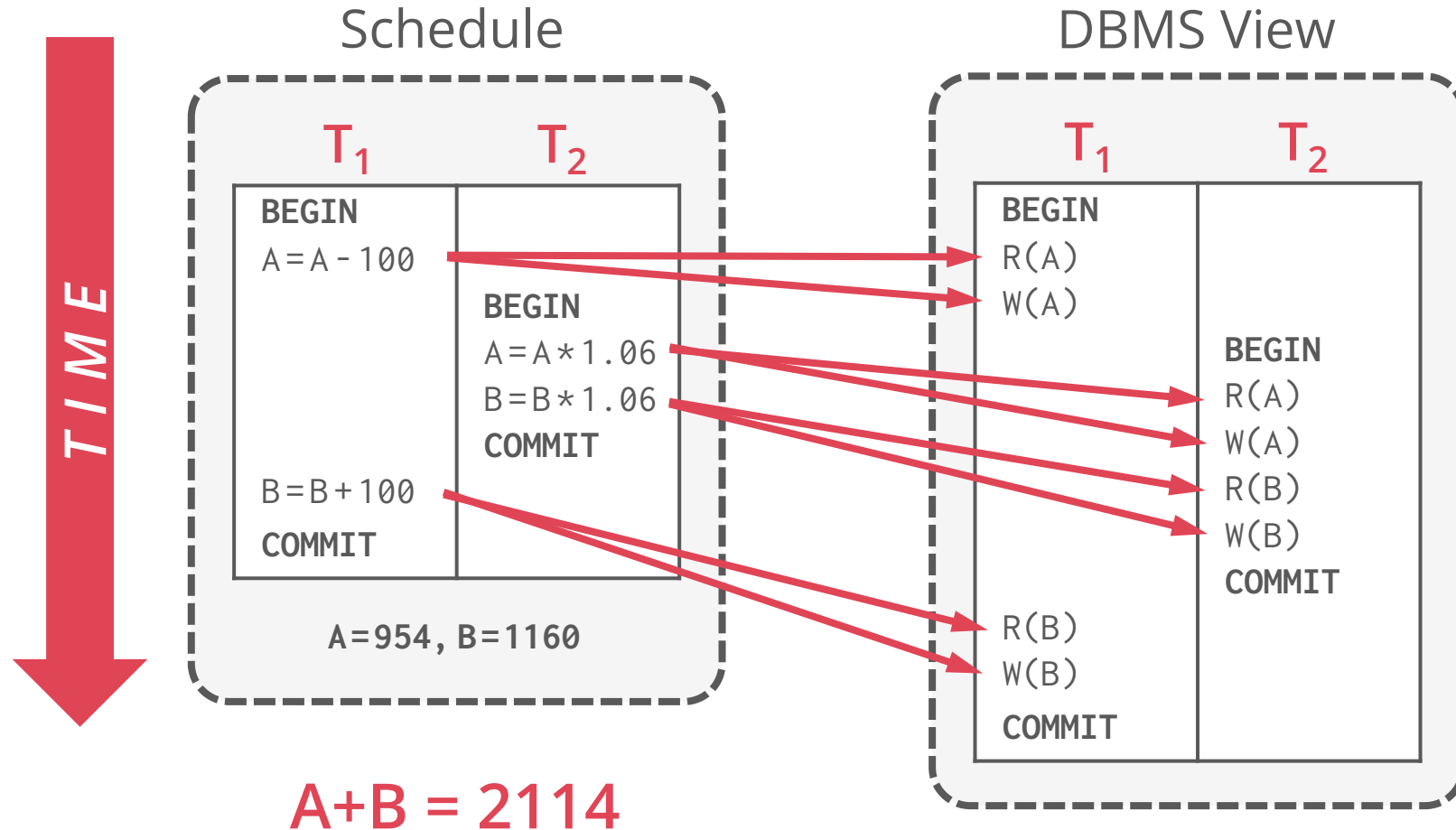

CORRECTNESS

How do we judge whether a schedule is correct?

If the schedule is **equivalent** to some **serial execution**

Schedule S for a set of transactions $\{ T_1, \dots, T_n \}$

S contains *all* steps of all transactions and order among steps in each T_i is *preserved*

S = $\langle (T_1, \text{read } \mathbf{B}), (T_2, \text{read } \mathbf{A}), (T_2, \text{write } \mathbf{B}), (T_1, \text{write } \mathbf{A}) \rangle$

for short, **S** = $\langle R_1(\mathbf{B}), R_2(\mathbf{A}), W_2(\mathbf{B}), W_1(\mathbf{A}) \rangle$

FORMAL PROPERTIES OF SCHEDULES

Equivalent schedules

For any database state, the effect of executing the first schedule is identical to the effect of executing the second schedule

Does not matter what the higher-level operations are!

Serial schedule (no concurrency)

A schedule that does not interleave the actions of different transactions

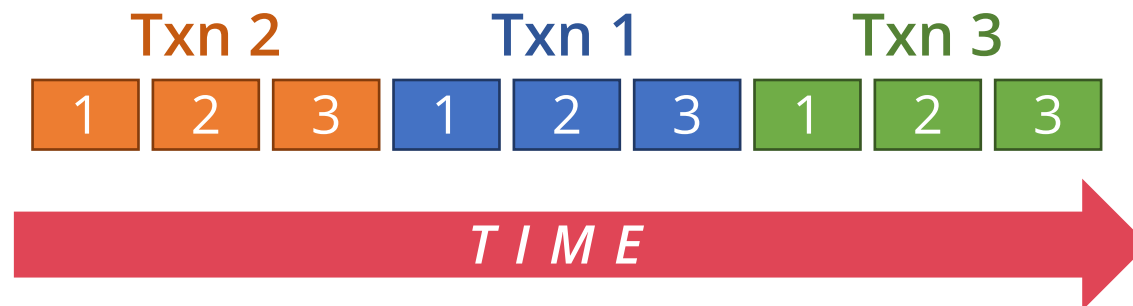

FORMAL PROPERTIES OF SCHEDULES

Serializable schedule

A schedule that is equivalent to some serial execution of the transactions

If each transaction preserves consistency, every serializable schedule preserves consistency

Serializability

Less intuitive notion of correctness compared to transaction initiation time or commit order

But it provides the DBMS with flexibility in scheduling operations

More flexibility means **better parallelism**

CONFLICTING OPERATIONS

We need a formal notion of equivalence that can be implemented efficiently based on the notion of “conflicting” operations

Two operations **conflict** if

- They are by different transactions

- They are on the same object and at least one of them is a write

Interleaved execution anomalies:

- Read-Write conflicts (R-W)

- Write-Read conflicts (W-R)

- Write-Write conflicts (W-W)

READ-WRITE CONFLICTS

Unrepeatable Reads

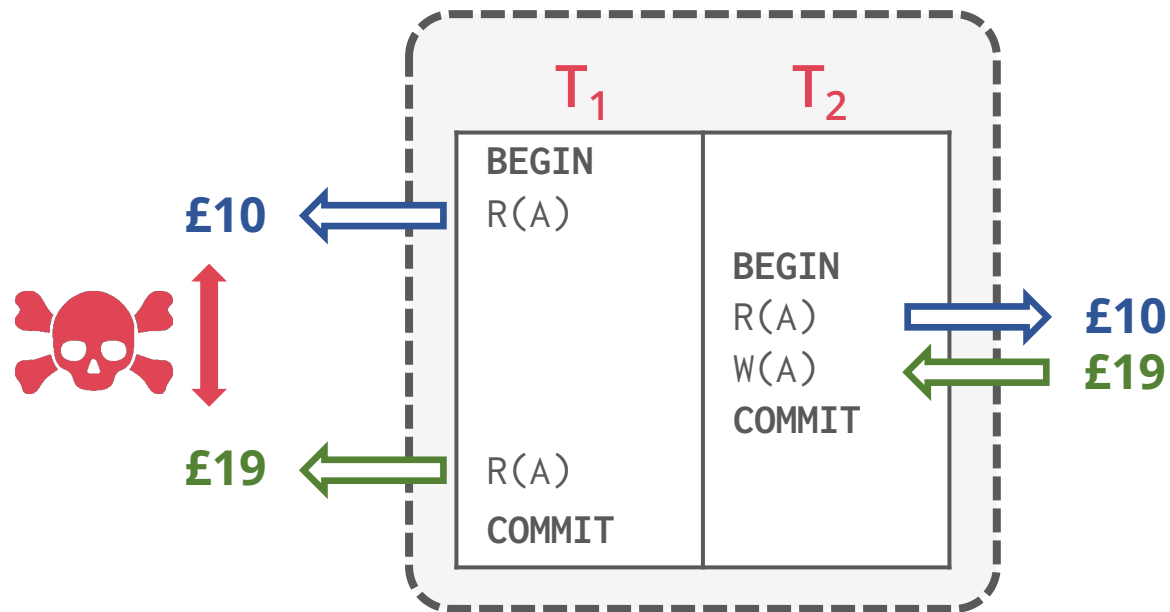

WRITE-READ CONFLICTS

Reading Uncommitted Data ("Dirty Reads")

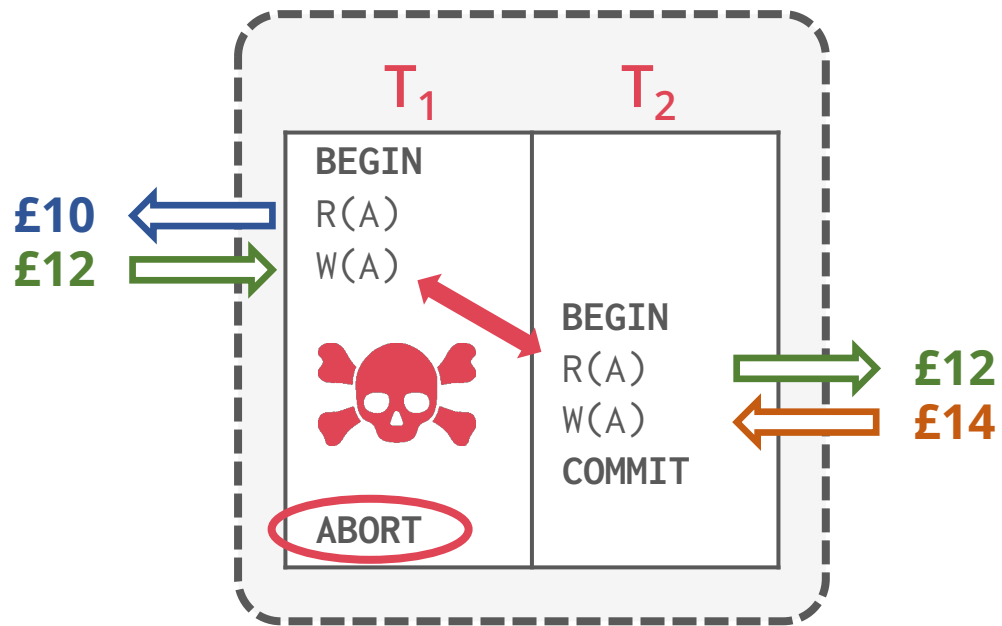

Not recoverable

WRITE-WRITE CONFLICTS

Overwriting Uncommitted Data ("Lost Update")

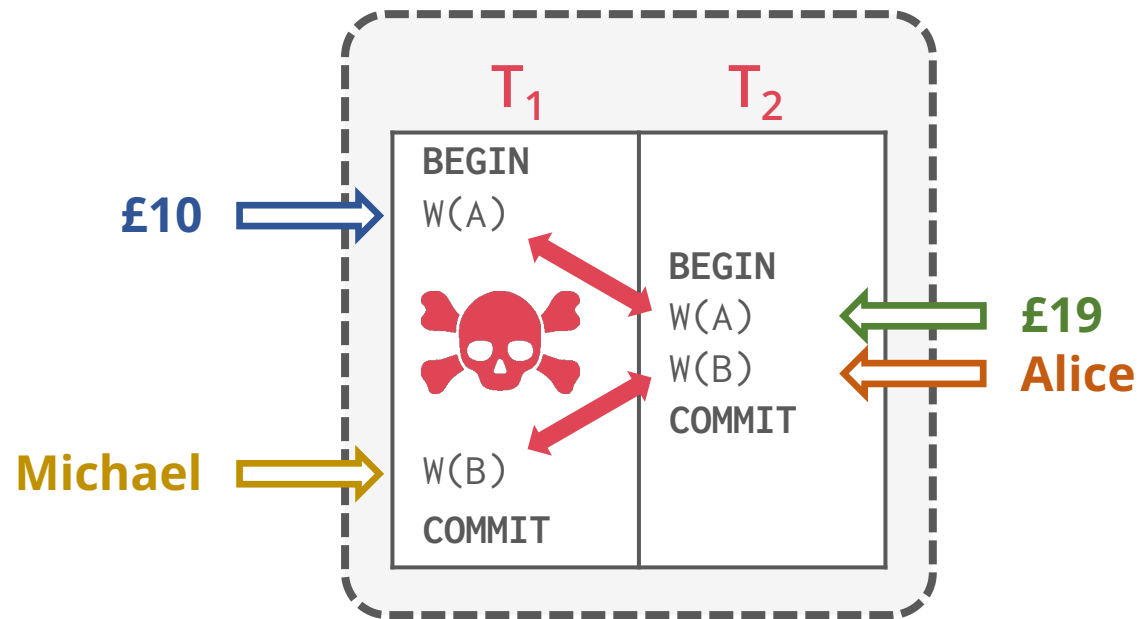

FORMAL PROPERTIES OF SCHEDULES

Given these conflicts, we can now understand what it means for a schedule to be serializable

This is to check whether schedules are correct

This is not how to generate a correct schedule

There are levels of serializability

Conflict Serializability

Most DBMS try to support this

View Serializability

No DBMS supports this

CONFLICT SERIALIZABLE SCHEDULES

Two schedules are **conflict equivalent** iff

They involve the same actions of the same transactions

Every pair of conflicting actions is ordered in the same way

Schedule **S** is **conflict serializable** if **S** is conflict equivalent to some serial schedule

*Intuition: Schedule **S** is conflict serializable if you can transform **S** into a serial schedule by swapping consecutive non-conflicting operations of different txns*

CONFLICT SERIALIZABILITY: INTUITION

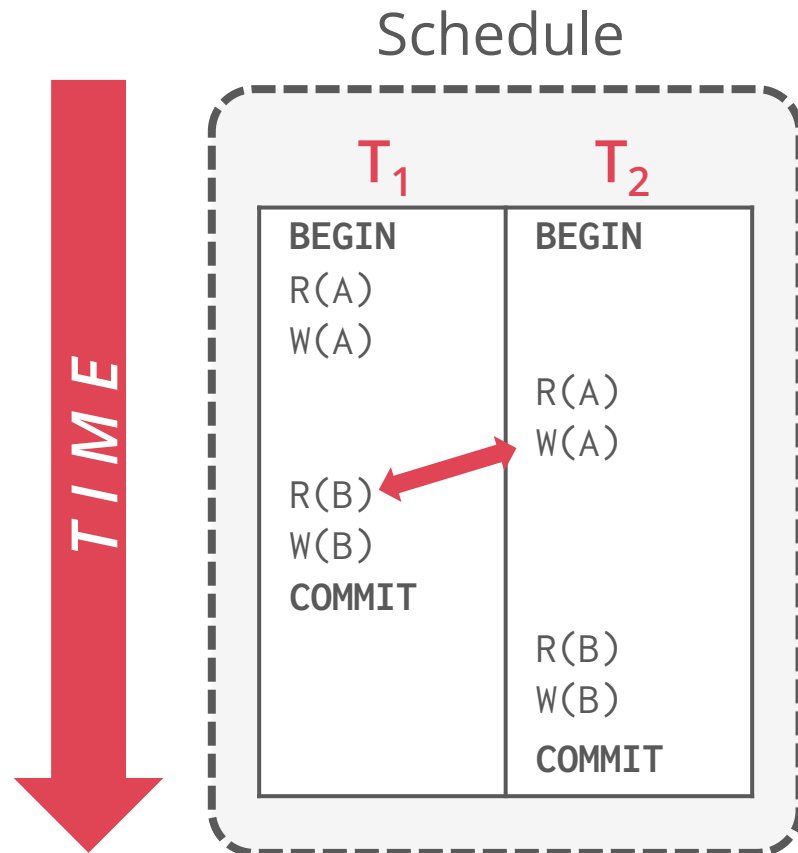

CONFLICT SERIALIZABILITY: INTUITION

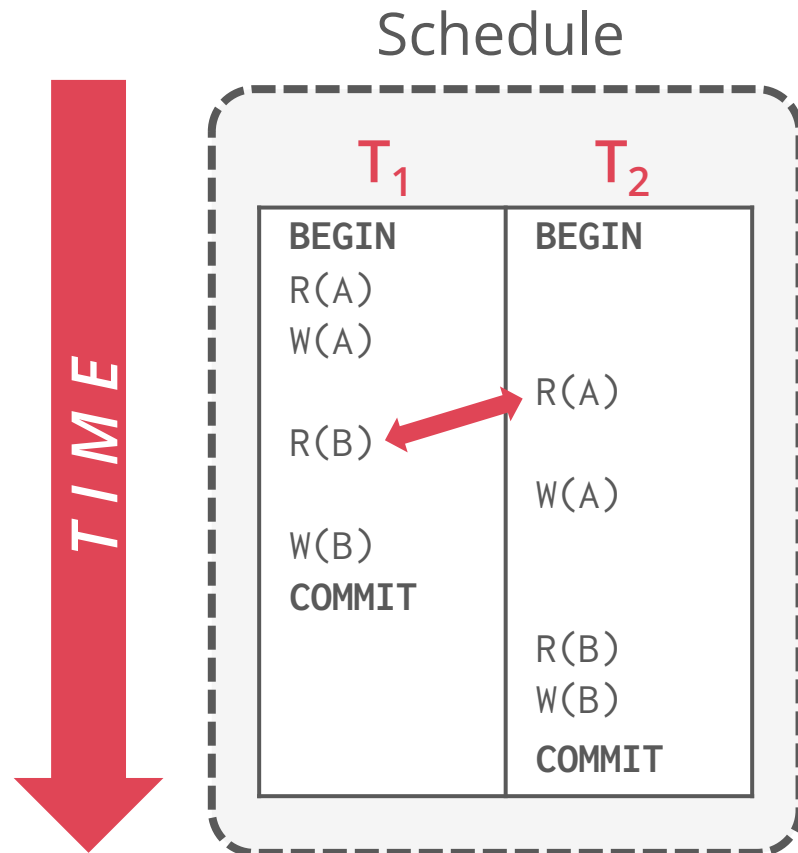

CONFLICT SERIALIZABILITY: INTUITION

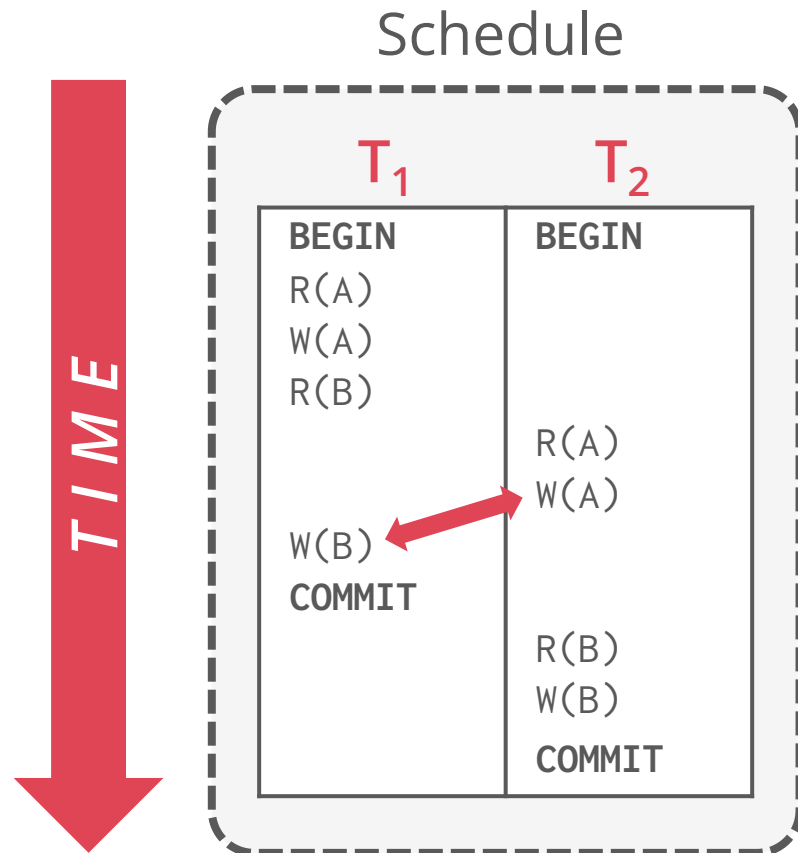

CONFLICT SERIALIZABILITY: INTUITION

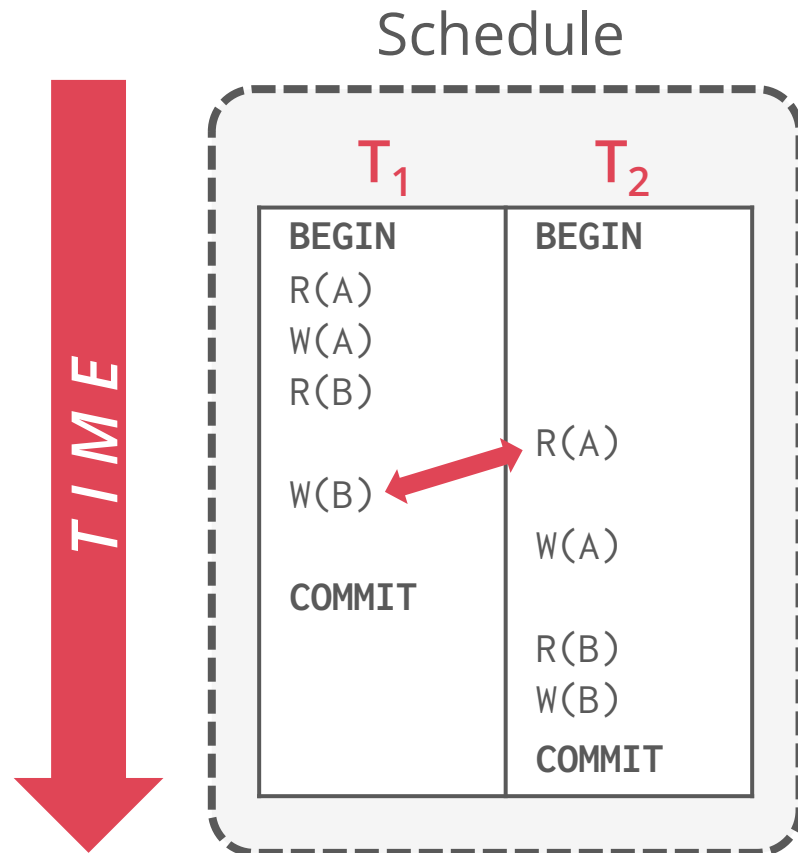

CONFLICT SERIALIZABILITY: INTUITION

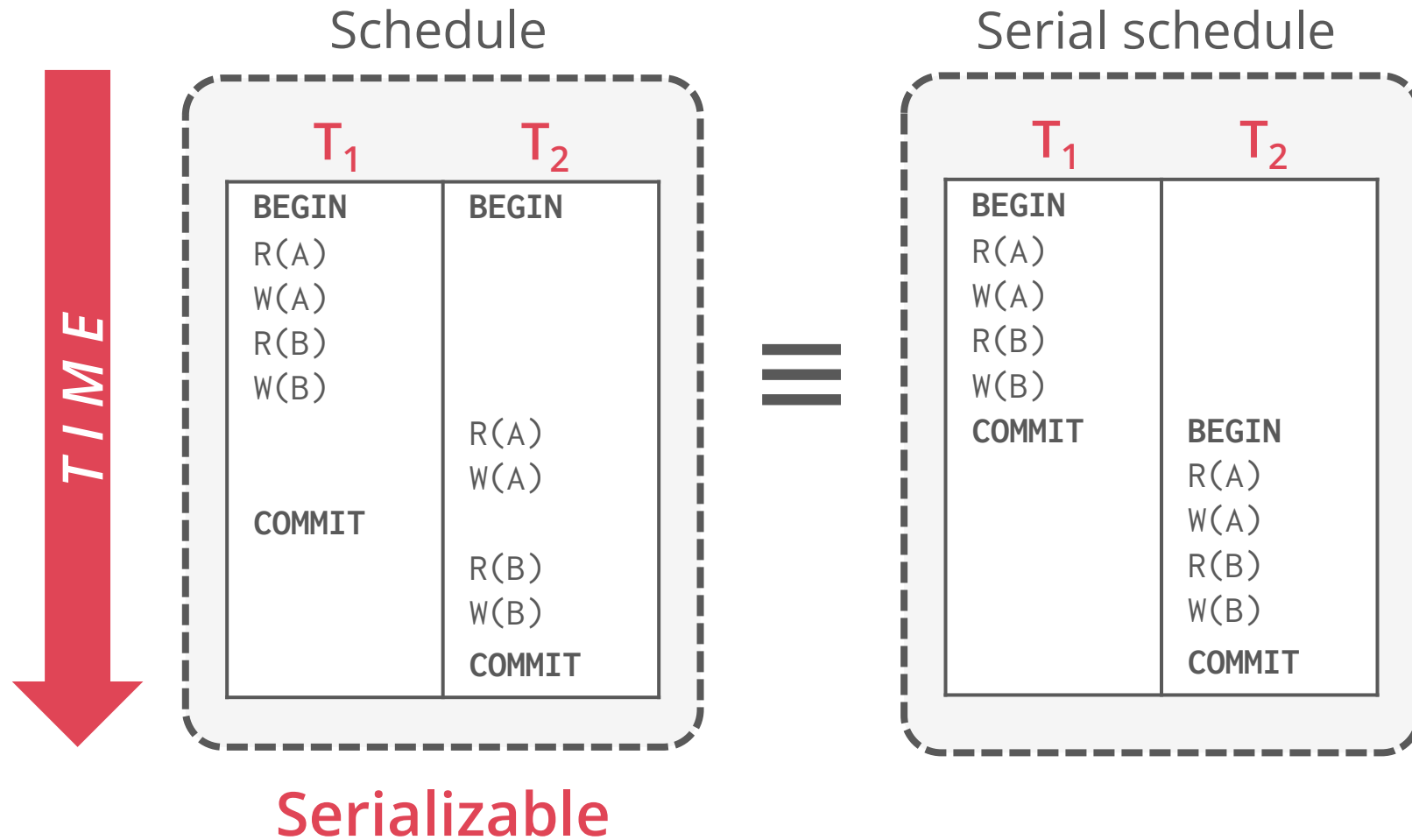

CONFLICT SERIALIZABILITY: INTUITION

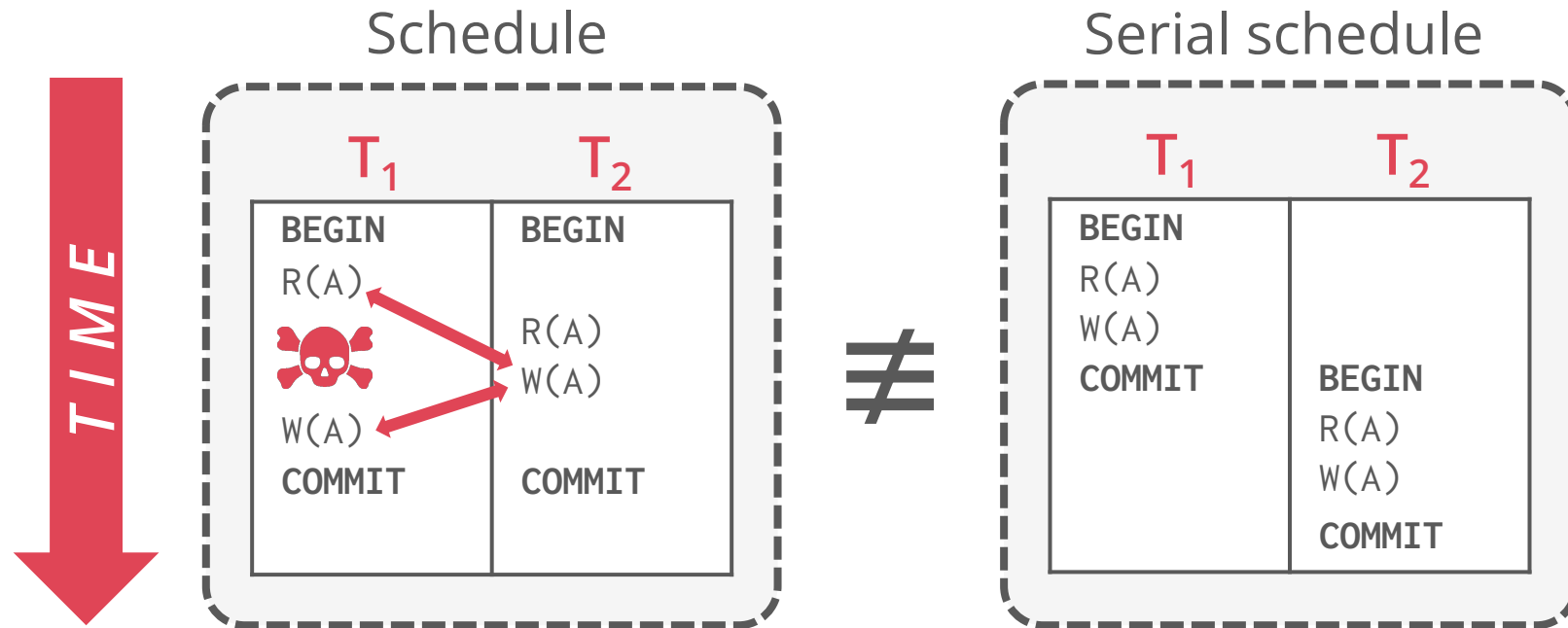

Not conflict-serializable

SERIALIZABILITY

Swapping operations is easy when there are only two txns in the schedule

But it's cumbersome when there are many txns

Are there any faster algorithms to figure this out other than transposing operations?

DEPENDENCY GRAPHS

Dependency graph for a schedule

One node per transaction

Edge from T_i to T_j if:

Operation O_i of T_i conflicts with an operation O_j of T_j and
 O_i appears earlier in the schedule than O_j

Also known as a **conflict graph** or **precedence graph**

A schedule is conflict-serializable if and only if
its dependency graph is acyclic

Equivalent **serial schedule** can be obtained by sorting the graph **topologically**

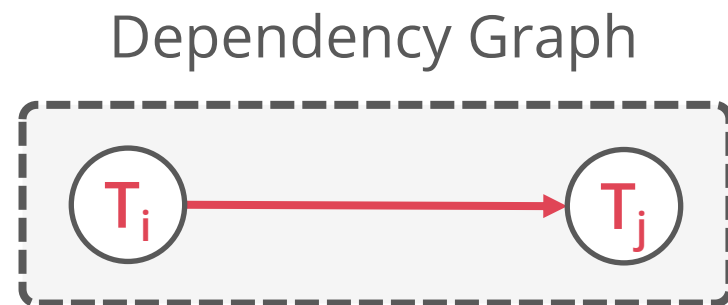

EXAMPLE #1

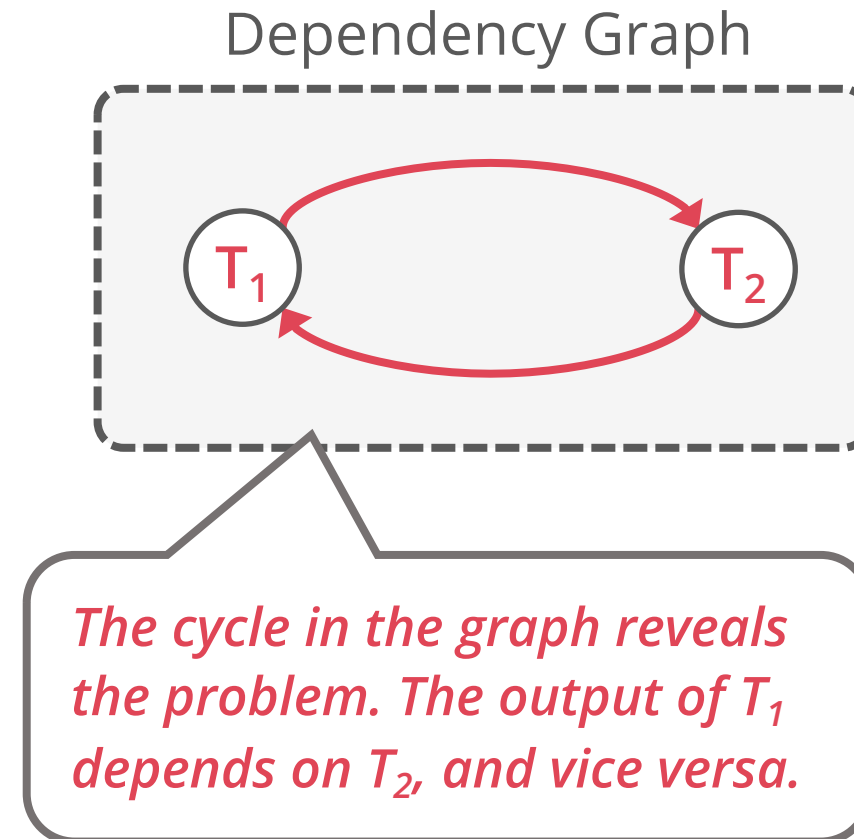
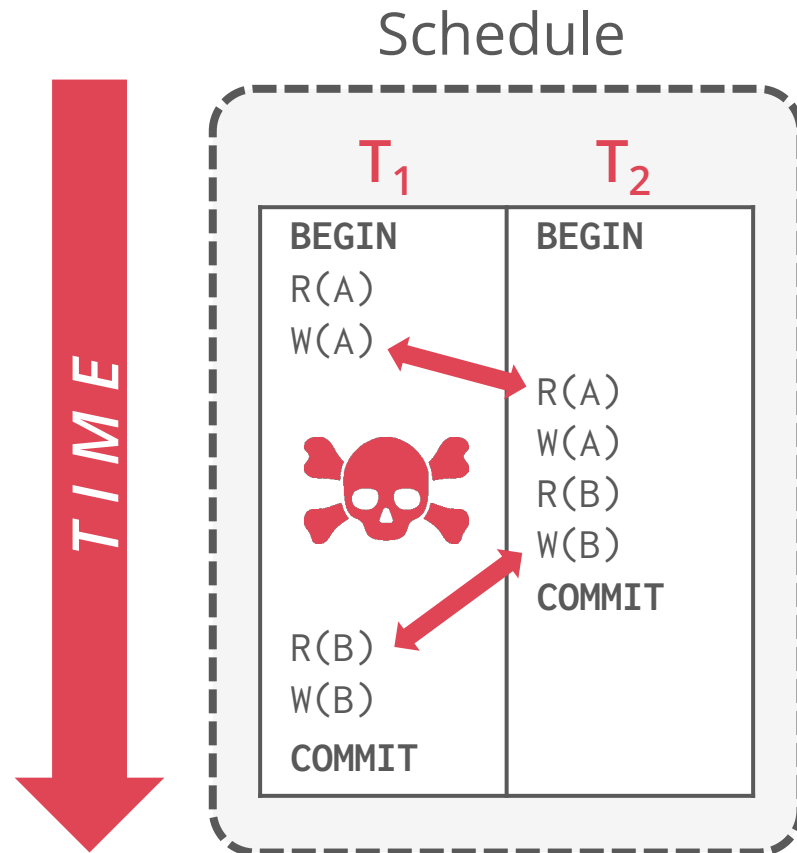

EXAMPLE #2 - THREESOME

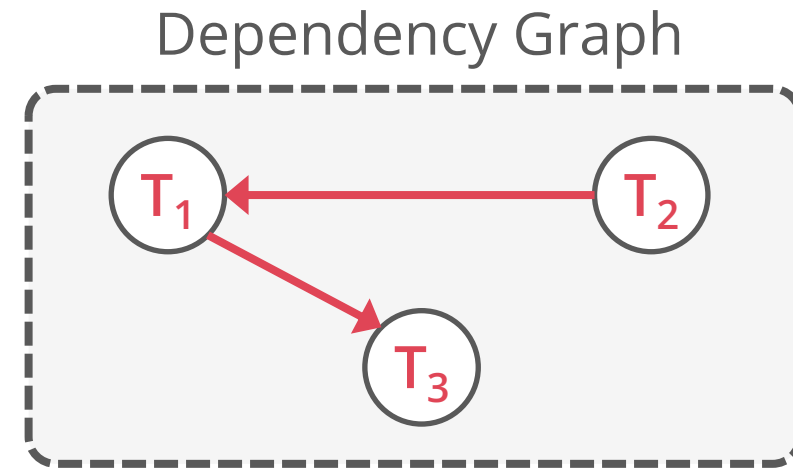
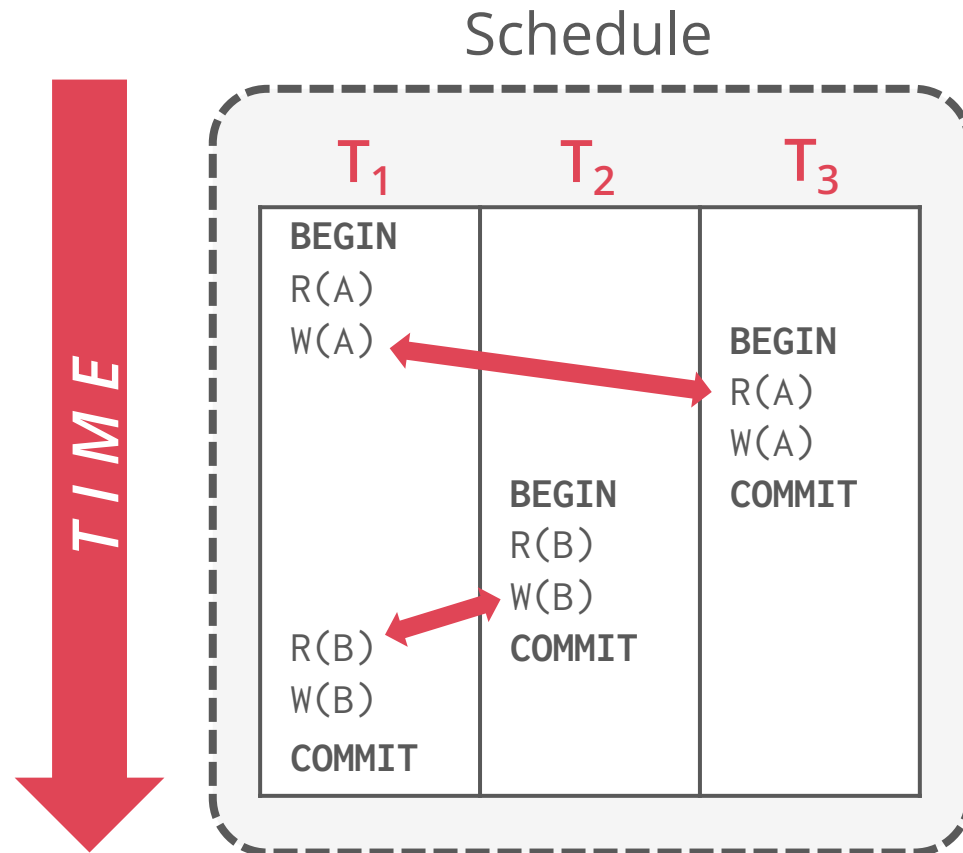

Is this equivalent to a serial schedule?

Yes, (T₂, T₁, T₃)

Notice that T₃ should go after T₂ although T₃ starts before T₂!

VIEW SERIALIZABILITY

Alternative (weaker) notion of serializability

Schedule S_1 and S_2 are **view equivalent** iff

If T_1 reads initial value of A in S_1 , then T_1 also reads initial value of A in S_2

If T_1 reads value of A written by T_2 in S_1 , then T_1 also reads value of A written by T_2 in S_2

If T_1 writes final value of A in S_1 , then T_1 also writes final value of A in S_2

VIEW SERIALIZABILITY

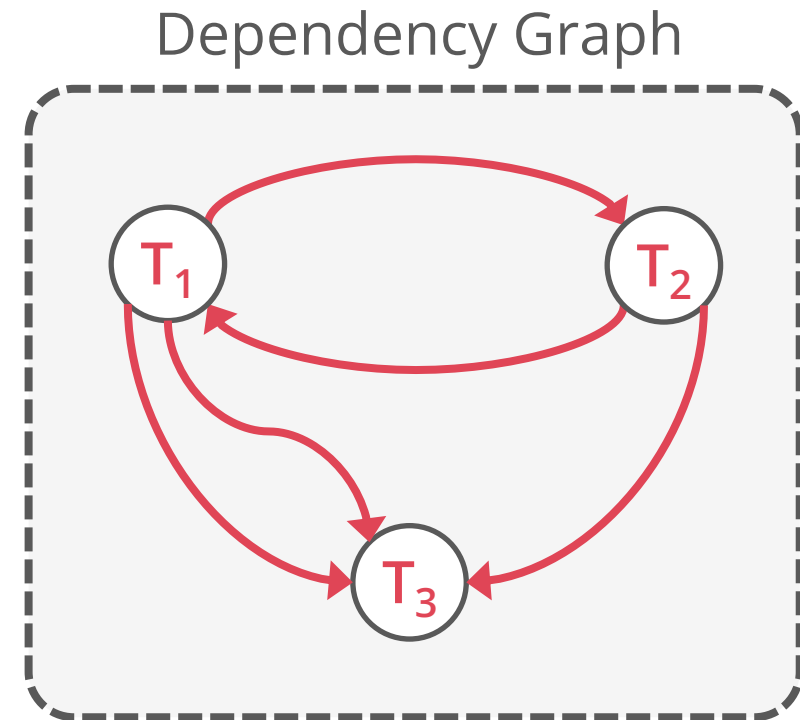
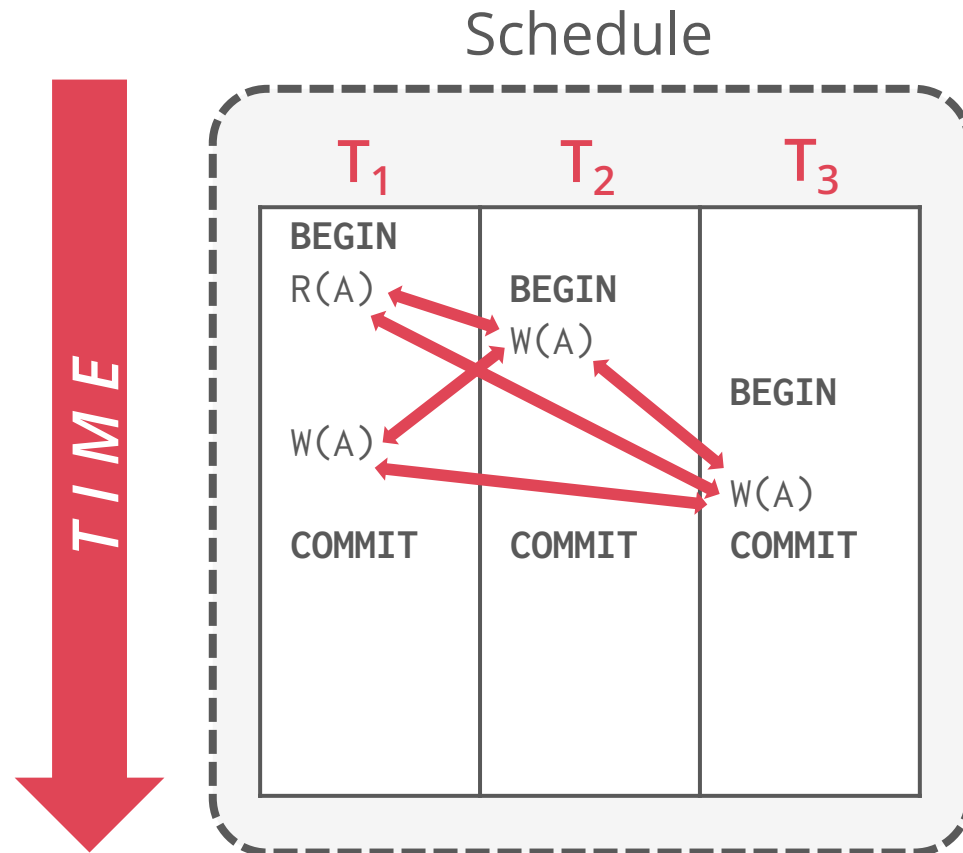

Not conflict serializable. But is this equivalent to a serial schedule?

VIEW SERIALIZABILITY

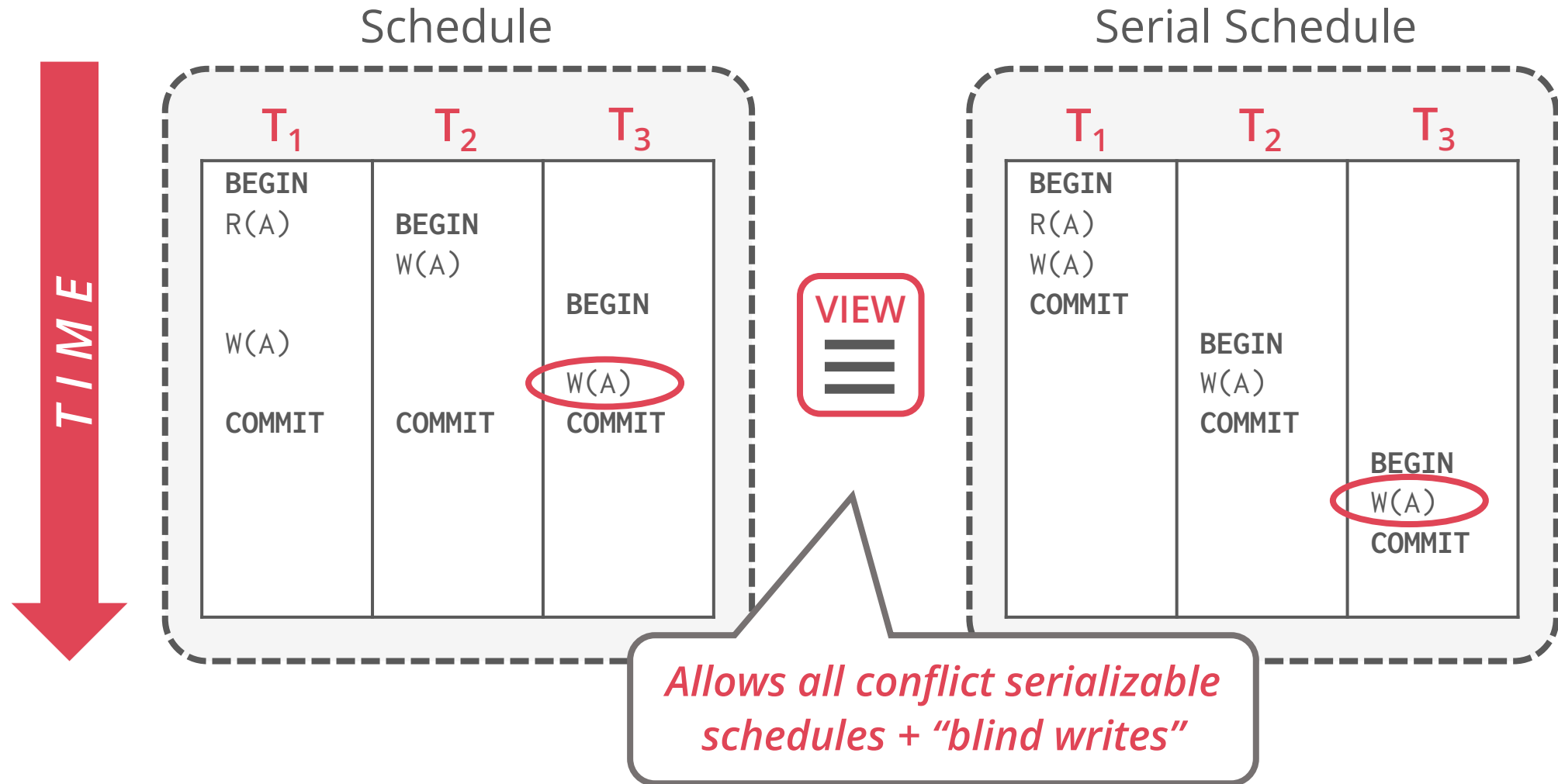

SERIALIZABILITY

Conflict serializability

Can be enforced efficiently

All DBMSs support it

View serializability

Admits (slightly) more schedules than CS

But it is difficult to enforce efficiently

No DBMS supports it

Neither definition allows all “serializable” schedules

They do not understand the meaning of the operations or the data

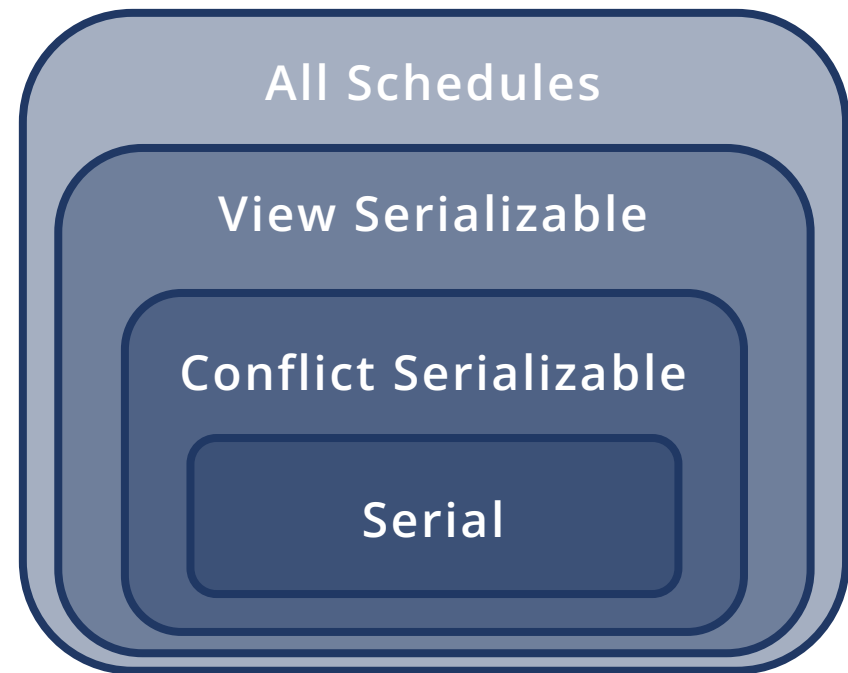

ACID PROPERTIES: DURABILITY

All of the changes of committed transactions must be persistent

- No torn updates

- No changes from failed transactions

The DBMS uses either logging or shadow paging to ensure that all changes are durable

More about logging in next lectures

SUMMARY

ACID Transactions

Atomicity: All or nothing

Consistency: Only valid data

Isolation: No interference

Durability: Committed data persists

Serializability

Serializable schedules

Conflict & view serializability

Checking for conflict serializability

Concurrency control and recovery are among the most important functions provided by a DBMS